

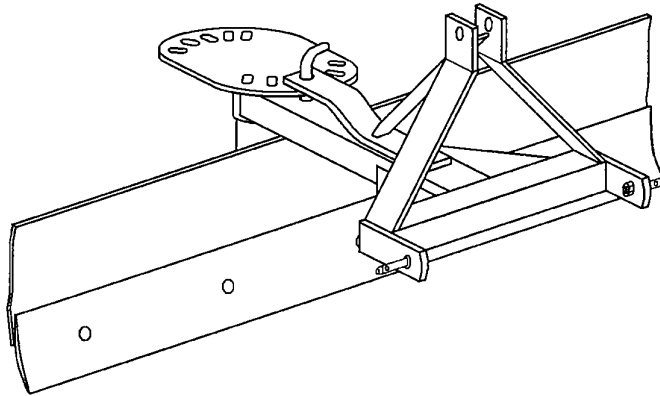

Taylor Pittsburgh Mfg., Inc.  
P.O. Box 1866  
Athens, TN 37371-1866  
423-745-3110

# FIELD GENERAL REAR BLADES



## OWNERS MANUAL

Form 233-RB-G/233-PRB/233-TRB-SC  
March 2008

## TABLE OF CONTENTS

WARRANTY INFORMATION .....	1
SAFETY SYMBOLS & SIGNAL WORDS .....	2
GENERAL INFORMATION.....	3
BOLT TORQUE CHART .....	3
TABLE OF CONTENTS .....	4
SPECIFICATIONS .....	4
SAFETY RULES .....	5 - 6
SAFETY DECALS & LOCATIONS .....	7
OPERATION.....	8
BEFORE OPERATION .....	8
ATTACHING .....	8
OPERATIONAL ADJUSTMENTS.....	8 - 10
TRANSPORTING .....	11
DETACHING .....	11
MAINTENANCE .....	11
STORAGE .....	11
REAR BLADE COMPONENTS .....	12 - 13

**TO THE DEALER:**

The rear blade assembly and proper installation to the tractor is the responsibility of the TAYLOR PITTSBURGH dealer. Read manual instructions and safety rules. Make sure all items on the Pre-delivery and Delivery Check Lists are completed before releasing equipment to the owner.

**TO THE OWNER:**

Read this manual before operating your TAYLOR PITTSBURGH rear blade. The information presented will prepare you to do a better and safer job. Keep this manual handy for ready reference. Require all operators to read this manual carefully and become acquainted with all the adjustment and operating procedures before attempting to operate. Replacement manuals can be obtained from your dealer or by calling 1-423-745-3110, in the USA and Canada only.

The rear blade you have purchased has been carefully engineered and manufactured to provide dependable and satisfactory use. Like all mechanical products, it will require cleaning and upkeep. Lubricate the unit as specified. Observe all safety information in this manual and safety decals on the rear blade and tractor.

For service, your authorized TAYLOR PITTSBURGH dealer has trained mechanics, genuine TAYLOR PITTSBURGH service parts, and the necessary tools and equipment to handle all your needs.

Provide this information to your dealer to obtain correct repair parts.

**LIMITED WARRANTY**

TAYLOR PITTSBURGH MFG., INC., the manufacturer, warrants only to the Original Purchaser that this equipment, under normal use and service, will be free from defects in material and workmanship for one (1) year from date of purchase providing this equipment is purchased for individual and not for commercial use. Warranty for commercial usage is 90 days. This warranty does not apply to any equipment which has been damaged or which has been subjected to abuse, misuse, negligence, abnormal wear and tear, alterations, tampering, or failure to follow operating instructions. This warranty does not cover any product or parts not manufactured by Taylor Pittsburgh Manufacturing, Inc..

Under this warranty, the manufacturer will repair or replace any part which the manufacturer determines has failed during the period of the warranty due to defects in material or workmanship. After approval by the manufacturer, the equipment or defective part must be returned to Taylor Pittsburgh Mfg., Inc., Athens, Tennessee 37371.

**PURCHASER'S EXCLUSIVE REMEDY FOR BREACH OF WARRANTY, OTHER DEFECT, OR CONDUCT GIVING RISE TO LIABILITY SHALL BE THE REPAIR OR REPLACEMENT OF THE PRODUCT SOLD, AND THE MANUFACTURER UNDER NO CIRCUMSTANCES SHALL BE LIABLE FOR ECONOMIC LOSS OR INCIDENTAL OR CONSEQUENTIAL DAMAGES. THE MANUFACTURER DISCLAIMS ALL IMPLIED WARRANTIES, INCLUDING THE WARRANTY OF MERCHANTABILITY AND FITNESS FOR PURPOSE.**

Taylor Pittsburgh Mfg., Inc. reserves the right to make improvements and changes in specifications without notice or obligation to modify previously sold units.

This manual describes the proper assembly procedures for your rear blade and furnishes operating and maintenance recommendations to help you obtain long and satisfactory service.

## SAFETY RULES



**ATTENTION! BECOME ALERT! YOUR SAFETY IS INVOLVED!**



### SAFETY ALERT SYMBOL

**FIG. 1:** This is the safety alert symbol. It means **ATTENTION: BECOME ALERT! YOUR SAFETY IS INVOLVED!** Look for it, both in this manual and on safety decals on the equipment. It will direct your attention to information that involves your safety and the safety of others.



Figure 1

### SIGNAL WORDS

**FIG. 2:** The words **DANGER**, **WARNING** or **CAUTION** are used with the safety alert symbol. Learn to recognize these safety alerts, and follow the recommended precautions and safe practices.

 **DANGER:** The safety alert symbol, with the word **DANGER**, indicates an imminently hazardous situation that, if not avoided, will cause **DEATH OR VERY SERIOUS INJURY**.

 **WARNING:** The safety alert symbol, with the word **WARNING**, indicates a potentially hazardous situation that, if not avoided, could cause **DEATH OR SERIOUS INJURY**.

 **CAUTION:** The safety alert symbol, with the word **CAUTION**, indicates a potentially hazardous situation that, if not avoided, may cause a **MINOR INJURY**.



Figure 2

Replace any **DANGER**, **WARNING**, **CAUTION** or instructional decal that is not readable or is missing. The location and part number of these decals is identified later in the section of the manual.

**IMPORTANT:** The word **IMPORTANT** is used to identify special instructions or procedures which, if not strictly observed could result in damage to, or destruction of the machine, process or its surroundings.

# GENERAL INFORMATION

## INTRODUCTION

**READ THIS MANUAL** carefully to learn how to properly operate and service your rear blade. Failure to do so could result in personal injury or equipment damage.

Throughout this manual, references are made to right and left direction. **RIGHT - HAND AND LEFT - HAND** sides are determined by standing behind the rear blade facing the direction the rear blade will travel when going forward.

The purpose of this manual is to assist you in operating and maintaining your Series 2 3 3 Rear Blade. Read it carefully. It furnishes information and instructions that will help you achieve years of dependable performance. These instructions have been compiled from extensive field experience and engineering data. Some information may be general in nature due to unknown and varying operating conditions.

However, through experience and these instructions, you should be able to develop procedures suitable to your particular situation.

Maintain your rear blade with original repair parts to insure safety and optimum performance.

The illustrations and data used in this manual were current at the time of printing, but due to possible production changes, your rear blade may vary slightly in detail. We reserve the right to redesign and change the machines as may be necessary without notification.

## BOLT TORQUE CHART

GRADE 2

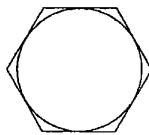

GRADE 5

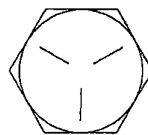

GRADE 8

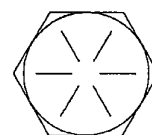

### TORQUE IN FOOT POUNDS (NEWTON METERS)

BOLT SIZE	3/8	1/2	5/8	3/4	7/8	1	
HEX HEAD	9/16	3/4	15/16	1-1/8	1-5/16	1-1/2	
GRADE	2	18 (24.4)	45 (61.0)	89 (120.7)	160 (216.9)	252 (341.6)	320 (433.9)
	5	30 (40.6)	68 (92.2)	140 (189.8)	240 (325.4)	360 (488.1)	544 (737.5)
	8	40 (54.2)	100 (135.6)	196 (265.7)	340 (460.9)	528 (715.1)	792 (1073.8)

<b>SPECIFICATIONS</b>			
<b>Description</b>	<b>233-RB-G</b>	<b>233-PRB</b>	<b>233-TRB-SC</b>
Moldboard Width - in. (mm)	60 (1524)	60 (1524)	60 (1524)
	72 (1905)	72 (1905)	-----
	84 (2133.6)	84 (2133.6)	-----
	-----	96 (2438.4)	-----
Moldboard Thickness - in. (mm)	1/4 (6.35)	1/4 (6.35)	1/4 (6.35)
Tractor (HP)	17 - 45	17 - 45	Up to 25
Three Point Hitch	CAT I	CAT I	CAT I
Angle Forward	0,15,30,45,60	0,15,30,45,60	0,15,30,45,60
Angle Reverse	0,15,30,45,60	0,15,30,45,60	0,15,30,45,60
Moldboard Height - in. (mm)	14 (356.2)	14 (356.2)	10 (254.4)
Cutting Edge - in. (mm)	1/2X6 (12.7X152.4)	1/2X6 (12.7X152.4)	1/2X6 (12.7X152.4)
Moldboard Tilt Angle	-----	6 Degrees	-----
Moldboard Offset - in. (mm)	-----	12 (304.8)	-----
	-----	Left or Right	-----
<b>Approximate Weight</b>			
60" (1524)	250 lbs.	-----	191 lbs.
72" (1905)	270 lbs.	320 lbs.	-----
84" (2133.6)	290 lbs.	340 lbs.	-----
96" (2438.4)	-----	360 lbs.	-----

# SAFETY RULES



**ATTENTION! BECOME ALERT! YOUR SAFETY IS INVOLVED!**



Your personal safety is a primary concern in the design and manufacture of our products. Unfortunately, our efforts to provide such equipment can be wiped out by a single careless act of an operator.

In addition to the design and configuration of equipment, hazard control and accident prevention are dependent upon the awareness, concern, prudence and proper training of personnel involved in the operation, transport, maintenance and storage of equipment.

It has been said **“The best safety device is an informed, careful operator.”** We ask you to be that kind of an operator.

The design of this equipment depends on it being operated within the limitations as explained in this manual.

## TRAINING

- Safety instructions are important! Read this manual and the tractor manual; follow all safety rules and safety decal information. (Replacement manuals are available from your dealer.) Failure to follow instructions or safety rules can result in serious injury or death.

- If you do not understand any part of this manual and need assistance, see your dealer.

- Know your controls and how to stop engine and attachment quickly in an emergency.

- The operator must be instructed in and be capable of the proper operation of the equipment, its attachments and all controls. Do not allow anyone to operate this equipment without proper instructions.

- Do not allow children or untrained persons to operate equipment.

## PREPARATION

- Always wear close fitting clothing and personal protection equipment called for by the job conditions. These items may include a hard hat, safety glasses, goggles or face shield, hearing protection and safety boots. DO NOT wear loose clothing, jewelry or any other items that may be entangled in moving parts. Tie up long hair.

- Ensure rear blade is properly mounted, adjusted and in good operating condition.

- Tighten all bolts and nuts and check that all cotter pins are installed securely to ensure equipment is properly assembled before operating.

- Tractor must be equipped with ROPS FRAME or ROPS CAB and seat belt. Keep seat belt securely fastened. Falling off tractor can result in death from being run over or crushed. Keep foldable ROPS systems in “locked up” position at all times.

- A minimum 20% of the combined tractor and rear blade weight must be on the tractor front wheels with rear blade in transport position. Without this weight, tractor could tip over causing personal injury or death. See your tractor operators manual for information regarding adding weights.

- Remove accumulated debris from this equipment, tractor and engine to avoid fire hazard.

- Ensure all safety decals are installed. Replace if damaged. (See Safety Decals section for location.)

## OPERATIONAL SAFETY

- Operate only in daylight or good artificial light.

- Always comply with all state and local lighting and marking requirements.

- No riders on equipment.

- Always sit in tractor seat with seat belt fastened when operating controls or starting engine. Place transmission in park or neutral, engage brake and ensure all other controls are disengaged before starting tractor engine.

- Look down and to the rear and make sure area is clear before operating in reverse.

- Do not operate on steep slopes

- Do not stop, start or change directions suddenly on slopes.

*(Safety Rules continued on next page)*



## SAFETY RULES



### ATTENTION! BECOME ALERT! YOUR SAFETY IS INVOLVED!

*(Safety Rules continued from previous page)*

- Use extreme care and reduce ground speed on slopes and rough terrain.
- Watch for hidden hazards on the terrain during operation.
- Stop tractor and implement immediately upon striking an obstruction. Turn off engine, remove key, inspect and repair any damage before resuming operation.
- When performing any service or maintenance disengage power to implement. Lower all raised components to the ground. Operate valve levers to release any hydraulic pressure. Stop engine, set parking brake and remove key before dismantling tractor.
- Keep all persons away from operator control area while performing adjustments, service or maintenance.

#### MAINTENANCE SAFETY

- Before working underneath, raise rear blade to highest position, install transport locks, and block securely. Blocking up prevents rear blade dropping from hydraulic leak down or mechanical failure on the tractor.
- Keep all persons away from operator control area while performing adjustments, service or maintenance.
- Your dealer can supply genuine replacement cutting edges. Substitute cutting edges may not meet original equipment specifications.
- Do not climb or walk on rear blade frame.

#### TRANSPORTING SAFETY

- Use a Slow - Moving - Vehicle (SMV) emblem and proper lighting on the tractor when transporting the rear blade.
- Do not drive the tractor and rear blade over 20 MPH (30 KPH) on the best surface conditions. Reduce speed when going up or down hills and when approaching ditches or corners.
- Always comply with all state and local lighting and marking requirements.
- Check condition of hitch pins and bolts before

transporting.

- Keep your rear blade in proper working condition. Unauthorized modifications to the rear blade may impair the function and affect rear blade life. Do not add excessive weight to rear blade. Additional weight could cause frame to fail resulting in loss of control of rear blade/tractor during transport.
- Raise rear blade to highest position for transport.
- Watch low hanging Overhead Power Lines during transport. Avoid contact as this can cause serious injury or death.

#### STORAGE

- Store on a level surface sheltered from the weather.
- Lower rear blade to the ground and block to prevent rolling.
- Clean all debris from rear blade.
- Coat soil engaging surfaces with a rust inhibitor after cleaning.
- Keep playing children and bystanders away from storage area.





## SAFETY DECALS



**ATTENTION! BECOME ALERT! YOUR SAFETY IS INVOLVED!**  
**Replace Immediately If Damaged!**

### DECAL LOCATIONS

The following safety decals are located on your implement. Read them and follow their instructions. Keep all decals in place and legible. Replace worn or missing decals. Replacement safety decals are available through your dealer. Order by number listed.

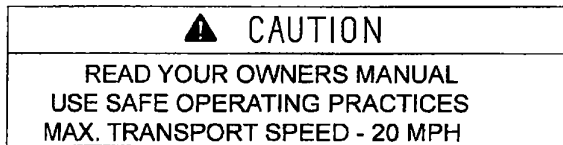

009537 - ON FRONT CROSS MEMBER OF FRAME

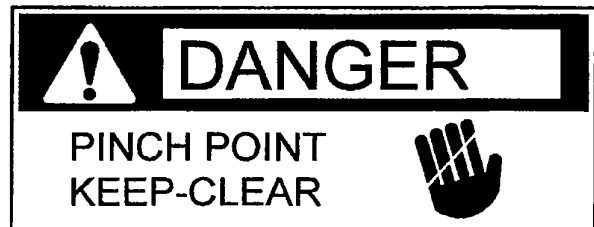

029772 - NEAR PIVOT BOLT ON TOP OF MAIN FRAME

# OPERATION

Your personal safety is a primary concern in the design and manufacture of our products. Unfortunately, our efforts to provide such equipment can be wiped out by a single careless act of an operator.

In addition to the design and configuration of equipment, hazard control and accident prevention are dependent upon the awareness, concern, prudence and proper training of personnel involved in the operation, transport, maintenance and storage of equipment.

It has been said "**The best safety device is an informed, careful operator.**" We ask you to be that kind of an operator.

The operator must be properly trained. Operators should be familiar with the rear blade and tractor and all safety practices before starting operation. Read the safety information on pages 2, & 5 through 8.

This rear blade is designed for normal farm usage.

Recommended blading speed for most conditions is from two to five mph.

Maintain your implement with original repair parts to insure optimum performance.

## MODIFICATIONS

---

It is the policy of the manufacturer to improve its products whenever possible and practical. We reserve the right to make changes, improvements, and modifications at any time without incurring the obligation to make such changes, improvements, and modifications on any implement sold previously.

## ASSEMBLY

---

### General

Your Series 233 Rear Blade is shipped fully assembled.

## BEFORE OPERATION

---

- 1) Tighten all loose hardware using the torque chart. Replace any missing hardware. On new machines, all hardware must be rechecked after first few hours of operation.
- 2) Replace any bent or broken parts.
- 3) Refer to your Tractor's Owner's Manual for recommended adjustments and weight distribution.

4) Check blade for signs of wear or damage. Replace if necessary. **SEE MAINTENANCE.**

5) Read the **SAFETY** section of this manual to be sure of all precautions.

## ATTACHING

---

### WARNING

**Be sure bystanders are clear. Do not stand between implement and tractor. Shut off tractor and engage parking brake prior to dismounting.**

- 1) Back tractor to align three--point lower arms with frame pins.
- 2) Attach left lower link arm to frame first and secure with click pin.
- 3) Using tractor right leveling crank, align right lower link arm with link pin. Attach arm to link pin and secure with click pin.
- 4) Attach top link between the frame and the tractor with a pin and secure with click pins.

## OPERATION

---

### Adjustments Depth Control:

The desired operating depth is selected by using the tractor's position control lever. When using position control, the blade will operate at the same depth, below the line of travel of the tires, until the setting is changed.

It is possible to operate the blade using draft control (if tractor is so equipped) when operating in the forward direction. When using draft control, the blade will operate at a depth which will result in a constant load on the tractor. **NEVER** operate with draft control when operating in the reverse direction with the moldboard reversed.

**Blade Moldboard Angle: (Refer to Figure 3)**  
Operating conditions for the job being done will largely determine the desired angle of the blade. A greater angle is generally used for cutting deep rather than for moving loose soil. As the blade is angled more, soil will roll and travel for a lesser distance, thus allowing a

deeper cut. It is suggested that the blade be angled sufficiently to permit soil to move freely in front of the blade.

The blade moldboard has an angle adjustment of 0°, 15°, 30°, and 45° to the left or right in the forward direction. Remove hairpin (2) and pin (3) and rotate moldboard (1) to desired angle. Replace pin and hairpin.

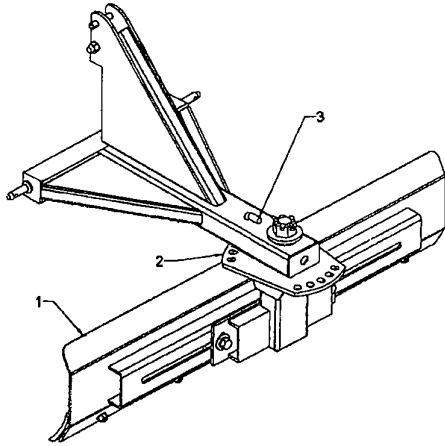
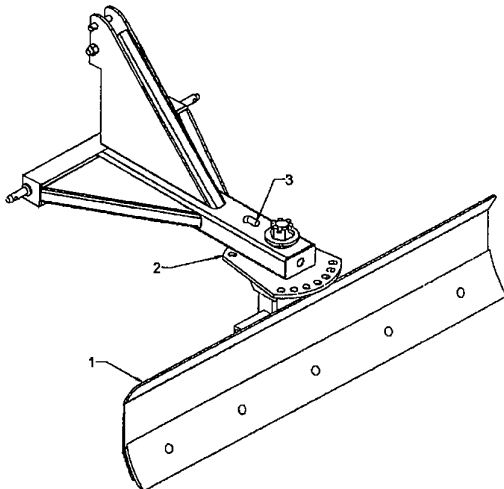

FIGURE 3

#### Reversing Moldboard (Refer to Figure 4)

The moldboard may also be reversed if desired. Remove hairpin (2) and angle adjustment pin (3). Rotate moldboard (1) completely around as shown and replace pin at desired angle. Secure with hairpin.



#### Blade Pitch (Refer to Figure 5)

The pitch of the blade can be changed by lengthening or shortening the tractor top link (1). Lengthening the top link increases blade "aggressiveness" and shortening the top link decreases blade "aggressiveness".

Adjust the blade pitch so that the soil tumbles ahead of the blade. Tumbling soil produces less draft and moves more earth. Normally, the upper edge of the moldboard is 1" to 2" (25 to 51MM) ahead of an imaginary vertical line extending upward from the cutting edge of the moldboard.

In general, working in harder soils requires more aggressiveness in order to dig in to the soil surface.

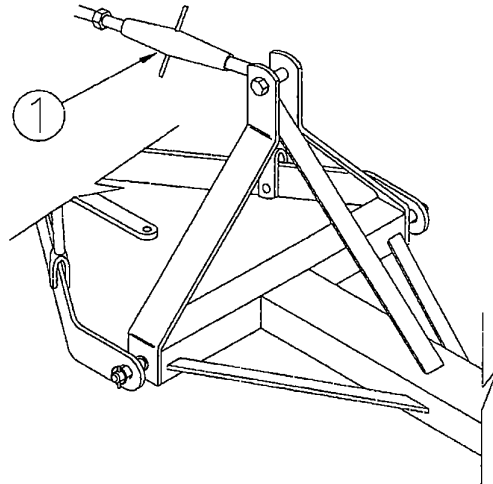

FIGURE 5

#### Blade Offset (Refer to Figure 6)

The blade can be offset up to 12" (304.8mm) by repositioning the moldboard on the pivot assembly. Lower blade to ground to remove moldboard weight. Loosen the two bolts (1 & 2) and reposition the moldboard at desired offset. Tighten bolts securely.

#### Blade Tilt (Refer to Figure 6)

The blade can be tilted right or left. Lower blade with one edge on a timber. Loosen bolts (1 & 2) and reposition blade to desired tilt. Tighten bolts securely.

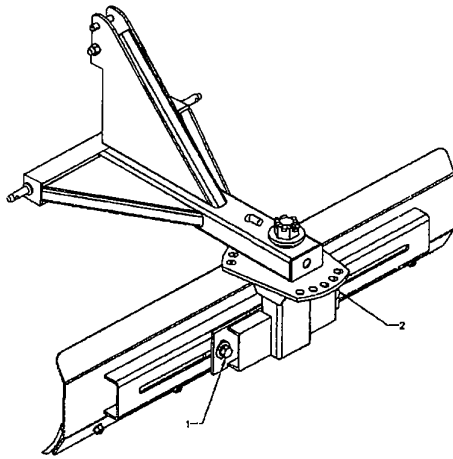

FIGURE 6

### Operating Terrace Construction:

In construction of a terrace system, the first terrace is always started near the top of the slope. Always prepare an outlet water channel before constructing a graded terrace. By starting at the top of the slope and completing the outlet channel, erosion damage, in the event of rain during construction, will be prevented.

### Blade Setting:

Set blade angle at 30° with the left--hand side of the blade forward. Raise the right--hand side of the blade to the desired cutting tilt by using the tractor right--hand lift link leveling crank. A first cut depth of 3" to 4" (76 to 102mm) is recommended although this may vary according to ground conditions.

### Terrace Layout:

The terrace is laid out as desired by marking the terrace course with stakes along the upper edge. The stakes provide a guide for the first cut which, on graded terraces, is started at the outlet channel. Follow the staked out course when making first shallow cut to mark out the terrace line.

On the return trip, the tractor is driven at a selected distance from the edge of soil deposited by blade on opening cut. This cut is also shallow and serves to mark lower edge of terrace.

### Second Cut:

The tractor front wheel should follow along the furrow wall made by the first cut with the blade lowered progressively deeper than the opening cut on the upper side of the terrace. On the lower side, make a cut slightly deeper than the opening cut.

### Additional Cuts:

On the upper side, drive the tractor so that the front wheel is evenly spaced above the furrow wall. This will permit the blade to move a cut of soil of the same width. Distance from front wheel to furrow wall edge determines the width of cut. Do not try too large a cut at any time. On the lower side, smaller cuts must be made if it is desired to increase the width of the terrace, since it is more difficult to roll soil uphill than downhill from upper edge of terrace.

### Moving Loose Soil

After each cut is made, move loose soil over onto terrace ridge. To complete ridge of terrace, additional soil is required. This is obtained from the area of the terrace designated as water channel. Cuts are made in channel until desired depth and sufficient soil for the terrace ridge has been obtained. Terrace is complete when all loose soil is cleared from water channel to provide a smooth channel.

### Terrace Profile:

The stakes mark location points of terrace. These points are:

- Upper edge of terrace
- Low point of water channel
- Crown of terrace ridge
- Lower edge of terrace

The ground below the terrace should be smoothed to blend into slope of adjoining undisturbed land. This prevents accumulation of water below ridge. Unless this ground blends into general slope, water will cause a soft spot in field and may start a gully.

The time required to construct a terrace and the number of rounds required to move loose soil will vary with soil type, local conditions, and size of terrace. The construction steps as outlined will be similar regardless of size or type of terrace being built. Discuss them with local conservation authorities.

By following these general suggestions, you will be able to build more terraces in less time.

### Back Filling

Reverse blade and operate at 0° to back fill ditches, etc.

### Drainage Ditch Construction

The rear blade lends itself readily to the construction of a V--type ditch used to drain surface water from wet

areas. To start a ditch, angle left end of blade 30° and lower the left end of the blade. Make necessary cuts to obtain desired ditch depth. At intervals during construction, it may be necessary to move soil away from edge of ditch.

### **Road Maintenance**

Maintenance of roads can easily be handled with a rear blade. The rear blade will do an efficient job of grading the road to a smooth surface.

### **Water Channel Construction**

The rear blade can be used to construct a broad bottom water channel, one of the types that is popular with soil conservationists. After each new cut, move soil to sides of channel and spread evenly over side area. Place a gradual slope on channel edges so that the channel can be crossed easily by implements.

## **TRANSPORTING**

---

- 1) Use a Slow - Moving - Vehicle (SMV) emblem and proper lighting on the tractor when transporting the rear blade.
- 2) Always comply with all state and local lighting and marking requirements.
- 3) Do not drive the tractor and rear blade over 20 MPH (30 KPH) on the best surface conditions. Reduce speed when going up or down hills and when approaching ditches or corners.
- 4) Check condition of hitch pins and bolts before transporting.
- 5) Raise rear blade to highest position for transport.
- 6) Travel at a speed safe for terrain and other conditions.
- 7) Keep your rear blade in proper working condition. Unauthorized modifications to the rear blade may impair the function, affect rear blade life, and put you at risk. Do not add excessive weight to rear blade. Additional weight could cause frame to fail resulting in loss of control of rear blade/tractor during transport.
- 8) Check local laws governing transport of farm equipment on public roads.
- 9) Use caution and be aware of oncoming traffic and roadside obstructions.

- 10) **DO NOT** transport on public roads at night.

## **DETACHING**

---

- Lower rear blade to the ground.
- Detach the tractor top link from the rear blade.
- Lower the blade frame unto supports and shut off tractor engine. Be sure blade is stable on supports.
- Detach tractor right hand lower link arm then left hand lower link arm from rear blade.

## **MAINTENANCE**

---

### **General**

Your rear blade is designed for minimum maintenance. By taking a few minutes prior to beginning operations and performing the following maintenance check, you will insure improved performance and longer life of your rear blade.

Keep cutting edge sharp for maximum performance. Reverse the cutting edge to get maximum use from both edges. Replace cutting edge as wear becomes excessive.

## **STORAGE**

---

- 1) Store on a level surface sheltered from the weather.
- 2) Lower equipment to the ground and block to prevent rolling.
- 3) Clean all debris from implement.
- 4) Coat soil engaging surfaces with a rust inhibitor after cleaning.
- 5) Keep playing children and bystanders away from storage area.

## REAR MOUNTED BLADE COMPONENTS

### Series 233-RB

Item	Part #	Description	Qty
1	233-RB-G-60	COMPLETE BLADE	1
	233-RB-G-72	COMPLETE BLADE	
	233-RB-G-84	COMPLETE BLADE	
2	813194	LOCK PIN	1
	304244	HAIRPIN COTTER	
3	303705	HHCS 3/4" X 4"NC	1
	304022	LOCKNUT 3/4"NC	
	952115	UPPER SLEEVE	
4	303113	CLICK PIN 3/8"	2
5	203266	Cat.I LINK PIN W/NUT	2
6	902016	CUTTING EDGE 60"	1
	815153	CUTTING EDGE 72"	
	900173	CUTTING EDGE 84"	
7	303942	PLOW BOLT 5/8"X1-3/4"	---
	304073	FLANGED NUT 5/8"	

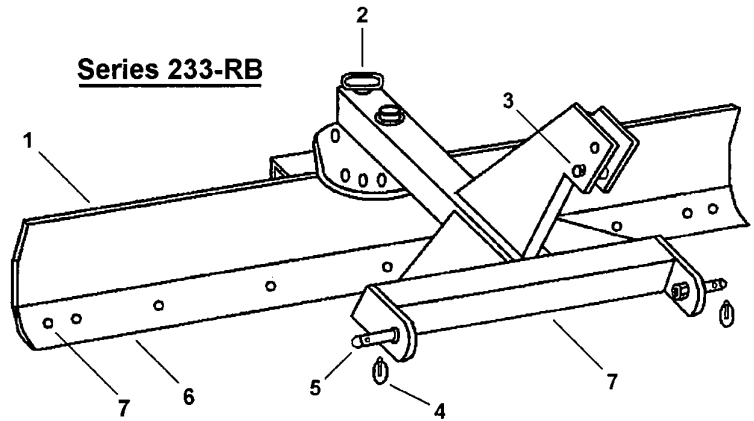

### Series 233-PRB

Item	Part #	Description	Qty
1	813184	MOLDBOARD 72"	1
	813185	MOLDBOARD 84"	
	813186	MOLDBOARD 96"	
2	813247	PIVOT WELDMENT	1
3	304142	COTTER PIN 5/16 X 3"	1
4	304042	CASTLE NUT 1-1/2"NC	1
5	303979	FLATWASHER 1-1/2"	1
	24438	HVY. FLATWASHER	
6	813194	LOCK PIN	1
	304244	HAIRPIN COTTER	
7	303705	HHCS 3/4" X 4"NC	1
	304022	LOCKNUT 3/4"NC	
	952115	UPPER SLEEVE	
8	813180	3pt. MAIN FRAME	1
9	303113	CLICK PIN 3/8"	2
10	203266	Cat.I LINK PIN W/NUT	2
11	815153	CUTTING EDGE 72"	1
	900173	CUTTING EDGE 84"	
	901999	CUTTING EDGE 96"	
12	303942	PLOW BOLT 5/8"X1-3/4"	---
	304073	FLANGED NUT 5/8"	
13	813257	SLIDE WELDMENT	2
	303701	HHCS 3/4" X 2-1/2"NC	
	303957	LOCKWASHER 3/4"	

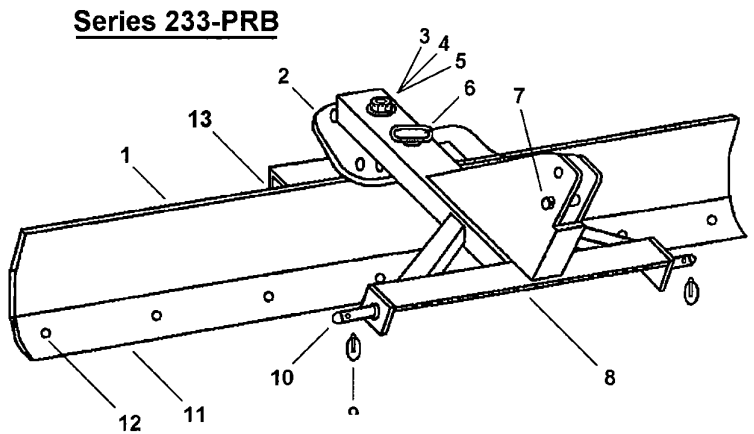

## SUB-COMPACT REAR BLADE COMPONENTS

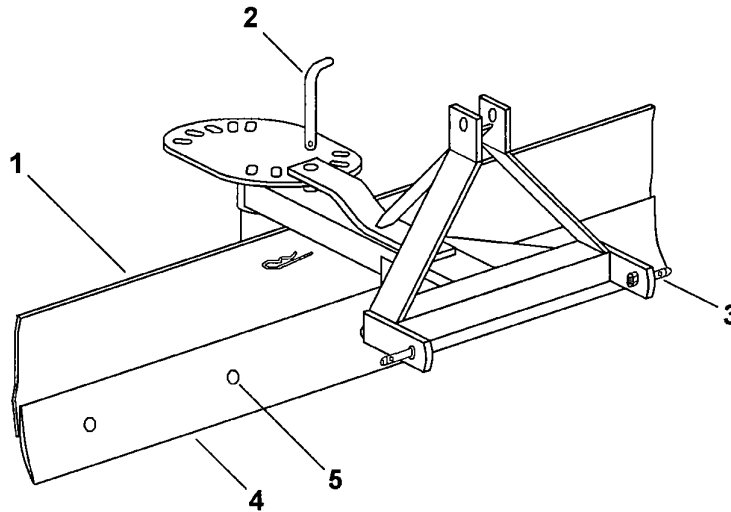

### Series 233-TRB-60-SC

Item	Part #	Description	Qty
1	233-TRB-60-SC	COMPLETE BLADE	1
2	340065	INDEX PIN	1
	304244	HAIRPIN COTTER	1
3	203266	Cat.I LINK PIN	2
4	188015	CUTTING EDGE 60"	1
5	303942	PLOW BOLT 5/8" X 1-3/4"	5
	304073	FLANGED NUT 5/8"	5

