

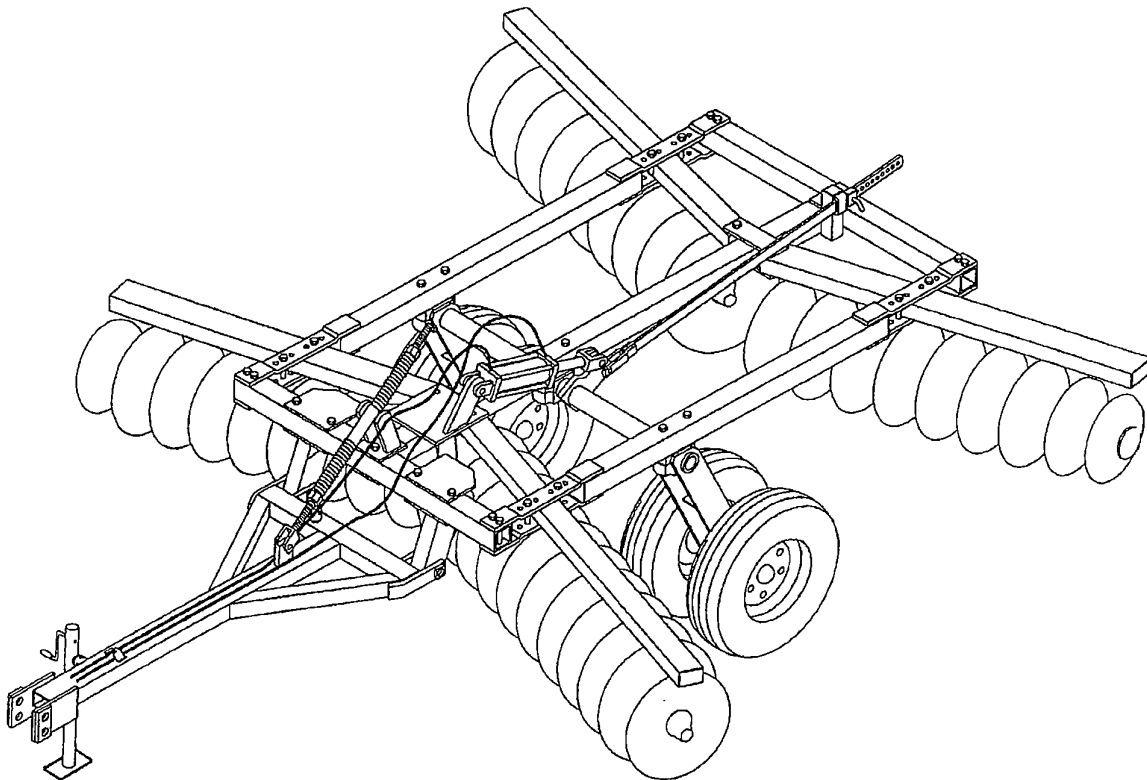

TAYLOR PITTSBURGH MFG., INC.
P.O. BOX 1866
ATHENS, TN 37371
423-745-3110

350/351 SERIES WHEEL MOUNTED TANDEM HARROW



OWNER'S MANUAL

NOVEMBER, 2007

TO THE DEALER:

The disk harrow assembly and proper installation to the tractor is the responsibility of the TAYLOR PITTSBURGH dealer. Read manual instructions and safety rules. Make sure all items on the Pre-delivery and Delivery Check Lists are completed before releasing equipment to the owner.

TO THE OWNER:

Read this manual before operating your TAYLOR PITTSBURGH disk harrow. The information presented will prepare you to do a better and safer job. Keep this manual handy for ready reference. Require all operators to read this manual carefully and become acquainted with all the adjustment and operating procedures before attempting to operate. Replacement manuals can be obtained from your dealer or by calling 1-423-745-3110, in the USA and Canada only.

The disk harrow you have purchased has been carefully engineered and manufactured to provide dependable and satisfactory use. Like all mechanical products, it will require cleaning and upkeep. Lubricate the unit as specified. Observe all safety information in this manual and safety decals on the disk harrow and tractor.

For service, your authorized TAYLOR PITTSBURGH dealer has trained mechanics, genuine TAYLOR PITTSBURGH service parts, and the necessary tools and equipment to handle all your needs.

Provide this information to your dealer to obtain correct repair parts.

LIMITED WARRANTY

TAYLOR PITTSBURGH MFG., INC., the manufacturer, warrants only to the Original Purchaser that this equipment, under normal use and service, will be free from defects in material and workmanship for one (1) year from date of purchase providing this equipment is purchased for individual and not for commercial use. Warranty for commercial usage is 90 days. This warranty does not apply to any equipment which has been damaged or which has been subjected to abuse, misuse, negligence, abnormal wear and tear, alterations, tampering, or failure to follow operating instructions. This warranty does not cover any product or parts not manufactured by Taylor Pittsburgh Manufacturing, Inc..

Under this warranty, the manufacturer will repair or replace any part which the manufacturer determines has failed during the period of the warranty due to defects in material or workmanship. After approval by the manufacturer, the equipment or defective part must be returned to Taylor Pittsburgh Mfg., Inc., Athens, Tennessee 37371.

PURCHASER'S EXCLUSIVE REMEDY FOR BREACH OF WARRANTY, OTHER DEFECT, OR CONDUCT GIVING RISE TO LIABILITY SHALL BE THE REPAIR OR REPLACEMENT OF THE PRODUCT SOLD, AND THE MANUFACTURER UNDER NO CIRCUMSTANCES SHALL BE LIABLE FOR ECONOMIC LOSS OR INCIDENTAL OR CONSEQUENTIAL DAMAGES. THE MANUFACTURER DISCLAIMS ALL IMPLIED WARRANTIES, INCLUDING THE WARRANTY OF MERCHANTABILITY AND FITNESS FOR PURPOSE.

Taylor Pittsburgh Mfg., Inc. reserves the right to make improvements and changes in specifications without notice or obligation to modify previously sold units.

This manual describes the proper assembly procedures for your disk harrow and furnishes operating and maintenance recommendations to help you obtain long and satisfactory service.

SAFETY RULES



ATTENTION! BECOME ALERT! YOUR SAFETY IS INVOLVED!



SAFETY ALERT SYMBOL

FIG. 1: This is the safety alert symbol. It means **ATTENTION: BECOME ALERT! YOUR SAFETY IS INVOLVED!** Look for it, both in this manual and on safety decals on the equipment. It will direct your attention to information that involves your safety and the safety of others.



Figure 1

SIGNAL WORDS

FIG. 2: The words **DANGER**, **WARNING** or **CAUTION** are used with the safety alert symbol. Learn to recognize these safety alerts, and follow the recommended precautions and safe practices.

 **DANGER:** The safety alert symbol, with the word **DANGER**, indicates an imminently hazardous situation that, if not avoided, will cause **DEATH OR VERY SERIOUS INJURY**.

 **WARNING:** The safety alert symbol, with the word **WARNING**, indicates a potentially hazardous situation that, if not avoided, could cause **DEATH OR SERIOUS INJURY**.

 **CAUTION:** The safety alert symbol, with the word **CAUTION**, indicates a potentially hazardous situation that, if not avoided, may cause a **MINOR INJURY**.



Figure 2

Replace any **DANGER**, **WARNING**, **CAUTION** or instructional decal that is not readable or is missing. The location and part number of these decals is identified later in the section of the manual.

IMPORTANT: The word **IMPORTANT** is used to identify special instructions or procedures which, if not strictly observed could result in damage to, or destruction of the machine, process or its surroundings.

GENERAL INFORMATION

INTRODUCTION

READ THIS MANUAL carefully to learn how to operate and service your harrow correctly. Failure to do so could result in personal injury or equipment damage.

Throughout this manual, references are made to right and left direction. **RIGHT - HAND AND LEFT - HAND** sides are determined by standing behind the harrow facing the direction the harrow will travel when going forward.

The purpose of this manual is to assist you in operating and maintaining your Series 350 Tandem Disc Harrow. Read it carefully. It furnishes information and instructions that will help you achieve years of dependable performance. These instructions have been compiled from extensive field experience and engineering data. Some information may be general in nature due to unknown and varying operating conditions.

However, through experience and these instructions, you should be able to develop procedures suitable to your particular situation.

Maintain your harrow with original repair parts to insure safety and optimum performance.

▲ WARNING

- **Some illustrations in this manual show the harrow with safety components removed to provide a better view. The harrow should never be operated with any safety components removed.**

The illustrations and data used in this manual were current at the time of printing, but due to possible production changes, your harrow may vary slightly in detail. We reserve the right to redesign and change the machines as may be necessary without notification.

BOLT TORQUE CHART

GRADE 2

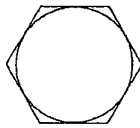

GRADE 5

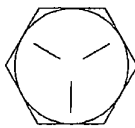

GRADE 8

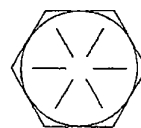

TORQUE IN FOOT POUNDS (NEWTON METERS)

BOLT SIZE		3/8	1/2	5/8	3/4	7/8	1
HEX HEAD		9/16	3/4	15/16	1-1/8	1-5/16	1-1/2
GRADE	2	18 (24.4)	45 (61.0)	89 (120.7)	160 (216.9)	252 (341.6)	320 (433.9)
	5	30 (40.6)	68 (92.2)	140 (189.8)	240 (325.4)	360 (488.1)	544 (737.5)
	8	40 (54.2)	100 (135.6)	196 (265.7)	340 (460.9)	528 (715.1)	792 (1073.8)

TABLE OF CONTENTS

WARRANTY	1
SAFETY SYMBOLS & SIGNAL WORDS	2
GENERAL INFORMATION.....	3
BOLT TORQUE CHART	3
SPECIFICATIONS	5
SAFETY RULES	6 - 7
SAFETY DECALS & LOCATIONS	8
INTRODUCTION	9
ASSEMBLY	9 - 13
BEFORE OPERATION	13
ATTACHING	14
OPERATION.....	14 - 15
ADJUSTMENTS	15 - 16
TRANSPORTING	16
MAINTENANCE.....	16 - 17
STORAGE	17
GANG LAYOUT DIAGRAMS.....	18 - 21
• Figure 6 - Small & Large Frame Components	22
• Figure 7 - Hitch Components	23
• Figure 8 - Wing Hinge Components.....	23
• Figure 9 - Large & Small Frame Wheel Lift Components	24
• Figure 10 - Wheel Hub Components	25
• Figure 11 - Disc Gang Components	26
• Table 1 Disc Blades	27
• Figure 12 - Spring Scraper Components	28
• Figure 13 - Rigid Scraper Components	29
• Table 2 & 3 Scraper Bar Listings	30
• Figure 14 - 15 - Hydraulic Cylinder & Circuit Components	31 - 32
• Figure 16-18 - Balk Breaker, Furrow Filler & Scraper Kits	33 - 34
• Miscellaneous Hardware.....	34

STANDARD EQUIPMENT**NARROW FRAME****LARGE FRAME**

Width of Cut: 351 Series	9' 3" to 12' 2" (Non-Fold)	12' 10" to 16' 4" (Non-Fold)
Width of Cut: 350 Series	14' 10" to 17' 8" (Wing Fold)	18' 8" to 21' 11" (Wing Fold)
Average Weight/Blade	119 Lbs.	100 Lbs.
Disc Blade Spacing	7-1/2", 9", 9" Front & 7-1/2" Rear	7-1/2", 9", 9" Front & 7-1/2" Rear
Disc Blade Size	20" or 22" Diameter	20" or 22" Diameter
Tapered Blades	(1) 2" on front	(1) 2" on front
	(2) on Rear (2" & 4" Reduction)	(2) on Rear (2" & 4" Reduction)
Frame Tube Size	4" x 4" x 3/8" Wall	4" x 4" x 3/8" Wall
Gang Tube Size	3" x 5" x 3/8" Wall	3" x 5" x 3/8" Wall
Disc Gang Angle	15°, 18°, 21°	15°, 18°, 21°
Gang Axle	1-1/8" Rd Corner Sq. High Carbon	1-1/8" Rd Corner Sq. High Carbon
Disc Spacers	Machined Ductile Iron	Machined Ductile Iron
Disc Gang Bearings	1-1/8" Square-Regreasable	1-1/8" Square-Regreasable
Bearing Seal	Triple Lip Seal	Triple Lip Seal
Rigid Bearing Connectors	Cast Ductile Iron	Cast Ductile Iron
Spring Bearing Connectors	1" x 2" Spring	1" x 2" Spring
Disc Blade Scrapers	Heat Treated High Carbon Steel	Heat Treated High Carbon Steel
Wheel Lift Pivot	Ductile Cast Bearing	Ductile Cast Bearing
Depth Control	Simple Adjusting Cuff & Pin	Simple Adjusting Cuff & Pin
Front to Rear Leveling	Adjustable Spring Rod	Adjustable Spring Rod
Hydraulic Cylinder Wheel Lift	4" x 8" Stroke	4" x 8" Stroke
Wing Hydraulic Cylinders (350)	3" x 16" (Four Required)	3" x 16" (Four Required)
Hydraulic Hoses	To Tractor, Less Tractor Fittings	To Tractor, Less Tractor Fittings
Transport Wheel Hubs	4	4
Transport Width (350)	10' 6"	14' 0"
Transport Clearance	10"	10"
Hitch	Single/Double Reversible Clevis	Single/Double Reversible Clevis
Tongue Jack	3000 #	3000 #

OPTIONAL EQUIPMENT	
DISC BLADES:	20" X 7 GAUGE CUT OUT OR ROUND DISCS
	22" X 6 GAUGE CUT OUT OR ROUND DISCS
STANDARD EQUIPMENT	
WHEEL RIMS	15" X 8"
TIRES	9.5L 15" -- 6 PLY
BALK BREAKER ATTACHMENT	PART #299088
FURROW FILLER ATTACHMENT	PART #201048
EXTRA EQUIPMENT	
FURROW FILLER SCRAPERS	PART #809694
GANG BOLT WRENCH	PART #209953

Rigid Brg Models (350-S)	Spring Brg Models (350-F)	Cutting Width	Number Of Discs	Approx. Weight Rigid Brg	Approx. Weight Spring Brg	Disc Spacing	Drawbar Horsepower Requirement
Narrow Frame Models Transport Width 10ft. 6in.							
350-S-48-77	350-F-48-77	15ft. 1in.	48	5,034	5,150	7-1/2" F/R	90
350-S-52-77	350-F-52-77	16ft. 3in.	52	5,239	5,399	7-1/2" F/R	95
350-S-56-77	350-F-56-77	17ft. 5in.	56	5,487	5,647	7-1/2" F/R	95
Narrow Frame Models Transport Width 10ft. 6in.							
350-S-40-99	350-F-40-99	14ft. 10in.	40	4,769	4,929	9" F/R	90
350-S-44-99	350-F-44-99	16ft. 3in.	44	5,017	5,177	9" F/R	95
350-S-48-99	350-F-48-99	17ft. 8in.	48	5,265	5,425	9" F/R	100
Narrow Frame Models Transport Width 10ft. 6in.							
350-S-44-97	350-F-44-97	15ft. 1in.	44	4,882	5,042	9F/7-1/2R	90
350-S-48-97	350-F-48-97	16ft. 3in.	48	5,130	5,290	9F/7-1/2R	95
350-S-52-97	350-F-52-97	17ft. 5in.	52	5,369	5,529	9F/7-1/2R	100
Wide Frame Models Transport Width 14ft. 6in.							
350-S-60-77	350-F-60-77	18ft. 8in.	60	6,010	6,250	7-1/2" F/R	115
350-S-64-77	350-F-64-77	19ft. 10in.	64	6,258	6,498	7-1/2" F/R	120
350-S-68-77	350-F-68-77	21ft.	68	6,506	6,746	7-1/2" F/R	125
Wide Frame Models Transport Width 14ft. 6in.							
350-S-52-99	350-F-52-99	19ft. 1in.	52	5,812	6,052	9" F/R	115
350-S-56-99	350-F-56-99	20ft. 6in.	56	6,037	6,277	9" F/R	120
350-S-60-99	350-F-60-99	21ft. 11in.	60	6,285	6,525	9" F/R	125
Wide Frame Models Transport Width 14ft. 6in.							
350-S-56-97	350-F-56-97	18ft. 8in.	56	5,902	6,142	9F/7-1/2R	115
350-S-60-97	350-F-60-97	19ft. 10in.	60	6,150	6,395	9F/7-1/2R	120
350-S-64-97	350-F-64-97	21ft.	64	6,403	6,643	9F/7-1/2R	125
Rigid Brg Models (351-S)	Spring Brg Models (351-F)	Cutting Width	Number Of Discs	Approx. Weight Rigid Brg	Approx. Weight Spring Brg	Disc Spacing	Drawbar Horsepower Requirement
Narrow Frame Models Wheel Tread 100" Width							
351-S-28-77	351-F-28-77	9ft. 3in.	28	3,932	4,029	7-1/2" F/R	55
351-S-32-77	351-F-32-77	10ft. 5in.	32	4,144	4,289	7-1/2" F/R	60
351-S-36-77	351-F-36-77	11ft. 6in.	36	4,356	4,550	7-1/2" F/R	65
Narrow Frame Models Wheel Tread 100" Width							
351-S-24-99	351-F-24-99	9ft. 4in.	24	3,842	3,940	9" F/R	55
351-S-28-99	351-F-28-99	10ft. 9in.	28	4,096	4,192	9" F/R	60
351-S-32-99	351-F-32-99	12ft. 2in.	32	4,350	4,495	9" F/R	65
Narrow Frame Models Wheel Tread 100" Width							
351-S-26-97	351-F-26-97	9ft. 3in.	26	3,890	3,987	9F/7-1/2R	55
351-S-30-97	351-F-30-97	10ft. 5in.	30	4,120	4,217	9F/7-1/2R	60
351-S-34-97	351-F-34-97	11ft. 6in.	34	4,356	4,525	9F/7-1/2R	65
Wide Frame Models Wheel Tread 136" Width							
351-S-40-77	351-F-40-77	12ft. 10in.	40	4,858	5,052	7-1/2" F/R	70
351-S-44-77	351-F-44-77	14ft.	44	5,112	5,306	7-1/2" F/R	75
351-S-48-77	351-F-48-77	15ft. 2in.	48	5,366	5,560	7-1/2" F/R	80
351-S-52-77	351-F-52-77	16ft. 4in.	52	5,620	5,814	7-1/2" F/R	85
Wide Frame Models Wheel Tread 136" Width							
351-S-36-99	351-F-36-99	13ft. 7in.	36	4,737	4,931	9" F/R	70
351-S-40-99	351-F-40-99	14ft. 10in.	40	4,997	5,191	9" F/R	75
351-S-44-99	351-F-44-99	16ft. 3in.	44	5,245	5,439	9" F/R	80
Wide Frame Models Wheel Tread 136" Width							
351-S-40-97	351-F-40-97	14ft.	40	4,925	5,118	9F/7-1/2R	75
351-S-44-97	351-F-44-97	15ft. 2in.	44	5,185	5,378	9F/7-1/2R	80
351-S-48-77	351-F-48-77	16ft. 4in.	48	5,433	5,627	9F/7-1/2R	85

SAFETY RULES



ATTENTION! BECOME ALERT! YOUR SAFETY IS INVOLVED!



Your personal safety is a primary concern in the design and manufacture of our products. Unfortunately, our efforts to provide safe equipment can be wiped out by a single careless act of an operator.

In addition to the design and configuration of equipment, hazard control and accident prevention are dependent upon the awareness, concern, prudence and proper training of personnel involved in the operation, transport, maintenance and storage of equipment.

It has been said “**The best safety device is an informed, careful operator.**” We ask you to be that kind of an operator.

The design of this equipment depends on it being operated within the limitations as explained in this manual.

TRAINING

- **Safety instructions are important! Read this manual and the tractor manual; follow all safety rules and safety decal information.** (Replacement manuals are available from dealer or call 1-800-456-7929.) Failure to follow instructions or safety rules can result in serious injury or death.
- **If you do not understand any part of this manual and need assistance, see your dealer.**
- **Know your controls and how to stop engine and attachment quickly in an emergency.**
- **Operators must be instructed in and be capable of the safe operation of the equipment, its attachments and all controls. Do not allow anyone to operate this equipment without proper instructions.**
- **Do not allow children or untrained persons to operate equipment.**

PREPARATION

- **Always wear close fitting clothing and personal protection equipment called for by the job conditions. These items may include a hard hat, safety glasses, goggles or face shield, hearing protection and safety boots. DO NOT wear loose clothing, jewelry or any other items that may be entangled in moving parts. Tie up long hair.**

- **Ensure implement is properly mounted, adjusted and in good operating condition.**
- **Tighten all bolts, nuts and bolts, and check that all cotter pins are installed securely to ensure equipment is properly assembled before operating.**
- **Tractor must be equipped with ROPS FRAME or ROPS CAB and seat belt. Keep seat belt securely fastened. Falling off tractor can result in death from being run over or crushed. Keep foldable ROPS systems in “locked up” position at all times.**
- **Remove accumulated debris from this equipment, tractor and engine to avoid fire hazard.**
- **Ensure all safety decals are installed. Replace if damaged. (See Safety Decals section for location.)**
- **Ensure shields and guards are properly installed and in good condition. Replace if damaged.**
- **A minimum 20% of a tractor and harrow weight must be on tractor front wheels with attachment in transport position. Without this weight, tractor could tip over causing personal injury or death. See your tractor operators manual for information regarding adding weight.**

OPERATIONAL SAFETY

- **Operate only in daylight or good artificial light.**
- **Always comply with all state and local lighting and marking requirements.**
- **Always comply with all state and local lighting and marking requirements.**
- **Always comply with all state and local lighting and marking requirements.**
- **No riders on equipment.**
- **Always sit in tractor seat with seat belt fastened when operating controls or starting engine. Place transmission in park or neutral, engage brake and ensure all other controls are disengaged before starting tractor engine.**
- **Use caution when working around sharp objects such as disc blades, tines, etc.**

(Safety Rules continued on next page)



SAFETY RULES



ATTENTION! BECOME ALERT! YOUR SAFETY IS INVOLVED!

(Safety Rules continued from previous page)

- Look down and to the rear and make sure area is clear before operating in reverse.
- Do not operate on steep slopes.
- Do not stop, start or change directions suddenly on slopes.
- Use extreme care and reduce ground speed on slopes and rough terrain.
- Watch for hidden hazards on the terrain during operation.
- Stop tractor and implement immediately upon striking an obstruction. Turn off engine, remove key, inspect and repair any damage before resuming operation.
- When performing any service or maintenance, disengage power to implement. Lower all raised components to the ground. Operate valve levers to release any hydraulic pressure. Stop engine, set parking brake and remove key before dismounting tractor.

MAINTENANCE SAFETY

- Before working underneath, raise harrow to highest position, install transport locks, and block securely. Blocking up prevents harrow dropping from hydraulic leak down or tractor failure.
- Serious injury can be inflicted by disc blades and disc gangs if not handled safely. Watch for unsafe conditions. Keep your coworkers safety in mind. Do not handle disc blades with bare hands.
- Keep all persons away from operator control area while performing adjustments, service or maintenance.
- Your dealer can supply genuine replacement disc blades. Substitute blades may not meet original equipment specifications.
- Do not stand on or straddle a tongue when unhitching.
- Never operate harrow until hydraulic cylinders and lines are full of oil and free of air. See operating instructions.
- Do not climb or walk on harrow frame, or tires.

TRANSPORTING SAFETY

- Use a Slow - Moving - Vehicle (SMV) emblem and proper lighting when transporting the harrow.
- Always use a safety chain of tensile strength equal to the gross weight of the disc harrow plus any attachments when transporting. Make sure that the weight of the towing vehicle EXCEEDS the weight of the harrow being towed. Stopping distance increases with increased speed as the weight of the towed load increases, especially on hills and slopes.
- Check tire pressure and wheel bolts before and during transport.
- Do not road the harrow over 20 miles per hour on the best surface conditions. Reduce speed when going up or down hills and when approaching ditches or corners. Towing vehicle must weigh more than towed implement.
- Check condition of hitch pins and bolts, tires and hubs, and safety chain before transporting.
- Keep your harrow in proper working condition. Unauthorized modifications to the harrow may impair the function and/or safety and affect harrow life. Do not add excessive weight to harrow. Additional weight could cause frame or axle to fail resulting in loss of control of harrow/tractor during transport.
- Watch low hanging Overhead Power Lines during transport. Avoid contact as this can cause serious injury or death.

STORAGE

- Lower disc harrow to the ground for storage and block to prevent rolling.
- Store on a level surface sheltered from the weather.
- Coat soil engaging surfaces with a rust inhibitor after cleaning.
- Keep playing children and bystanders away from storage area.



SAFETY DECALS



ATTENTION! BECOME ALERT! YOUR SAFETY IS INVOLVED!
Replace Immediately If Damaged!

DECAL LOCATIONS

The following decals are located on your implement. Read them and follow their instructions. Keep all decals in place and legible. Replace worn or missing decals. Order by number listed.

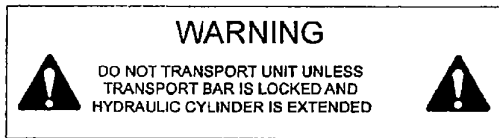

605176 - Front of Main Frame

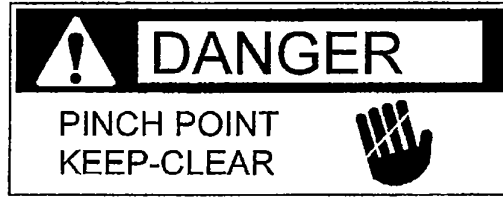

029772 - Wing Hinges & Hydraulic Lift

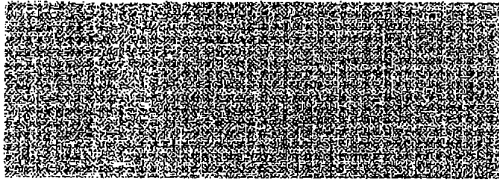

029770 - Amber Reflector - Front Outside Gang Tubes

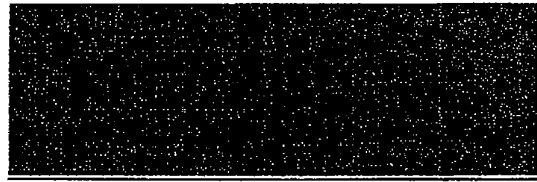

029771 - Red Reflector - Rear Outside Corner of Gang Tubes

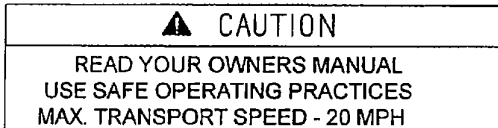

009537 - Front of Main Frame



029775 - Front of Main Frame

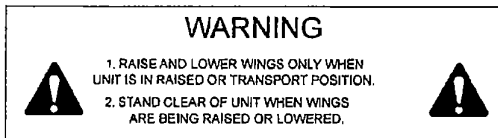

605177 - Front of Main Frame

OPERATION

INTRODUCTION

Safety is a primary concern in the design and manufacture of our products. Unfortunately, our efforts to provide safe equipment can be wiped out by a single careless act of an operator.

In addition to the design and configuration of equipment, hazard control and accident prevention are dependent upon the awareness, concern, prudence and proper training of personnel involved in the operation, transport, maintenance and storage of equipment.

It has been said “**The best safety device is an informed, careful operator.**” We ask you to be that kind of an operator.

The operator is responsible for the safe operation of this harrow. The operator must be properly trained. Operators should be familiar with the harrow and tractor and all safety practices before starting operation. Read the safety information on pages 2, & 5 through 8.

This disc harrow is designed for normal farm usage. Optional blades are available for different conditions.

Recommended harrowing speed for most conditions is from two to five mph.

Maintain your harrow with original repair parts to insure safety and optimum performance.

ASSEMBLY

General

Your Series 350 Tandem Disc Harrow is shipped in bundles for assembly. Remove all wiring from bundles as they are called for. Choose a level area to arrange the parts conveniently. Assemble parts for each step loosely to insure fit. Use flatwashers with slotted holes. Always use lockwashers unless a lock nut is called for. Tighten hardware after parts are installed according to the torque

chart on Page 7. Unless otherwise stated, all hardware is grade 5. The following assembly steps are given to minimize the need for adjustment after assembly. Remember that **LEFT** and **RIGHT** are determined by standing at the rear of the implement and facing it.

Main Frame Assembly (Refer to Figure 1)

The narrow frame harrow frame is shipped assembled from the factory. If you have a narrow frame harrow proceed to step 6.

1) Position the center frame in the middle of the work area. Block the center frame up approximately 24" off the ground. When assembling do not tighten hardware until assembly is complete.

2) Mount front cross frame to front of center frame. Install five 3/4" x 6-1/2" bolts in middle holes. Secure with lockwashers and nuts.

3) Mount rear cross frame, with slow moving vehicle emblem bracket facing to the rear, to the center frame using a 3/4" x 6-1/2" bolt. Secure with lockwasher and nut.

4) Remove hardware from the ends of the side frame bundles. Position side frames on front and rear cross frames with the wheel lift bearings to the front and down. Attach using two 3/4" x 6-1/2" bolts in each end. Secure with lockwashers and nuts.

5) Slide wheel lift assembly under the frame with cylinder bracket up and hubs to the rear. This assembly will be mounted later.

6) Identify the front and rear main frame gang bundles and differentiate left and right. Remember that the front disc blades are cupped to the outside and the rear are cupped to the inside, also the disc scrapers always go to the rear.

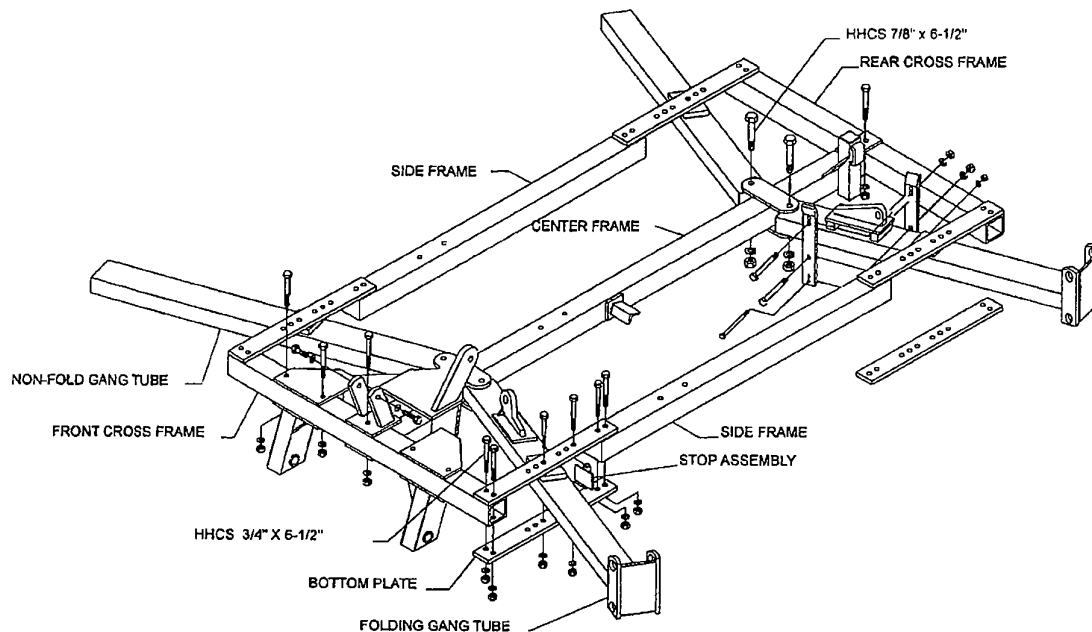

FIGURE 1 - FRAME & GANG ASSEMBLY

⚠ WARNING

Use care when handling disc gangs. Blades are very sharp. Wear heavy gloves.

7) Remove the 7/8" x 6-1/2" bolts from each gang frame cuff on center frame, then one at a time remove hardware and bottom plate from each side frame and slide that gang into position. Align end of gang frame with cuff holes on center frame, with two flatwashers on top on front gang frames and two flatwashers on bottom on rear gang frames, and reinstall bolt and hardware. Reinstall side frame bottom plate and hardware. Repeat this procedure for the remaining main frame gangs.

8) Although the gangs are mounted on the gang frame tubes from the factory, adjustments may be necessary to obtain the correct amount of rear balk and correct spacing between the discs on adjoining gangs. This can be easily accomplished by loosening the gang connector bolts and sliding the gang assembly on the tube until the correct spacing is obtained.

9) On a new harrow or one that has been adjusted according to step 8 be sure that gang hangers are square and tight to gang frame tube and disc blades rotate freely.

10) Adjust disc gangs to the desired angle and insert a gang stop assembly behind each gang tube within the side frame. Install a 3/4" x 6-1/2" bolt through the side frame and stop assembly and secure with lockwasher and

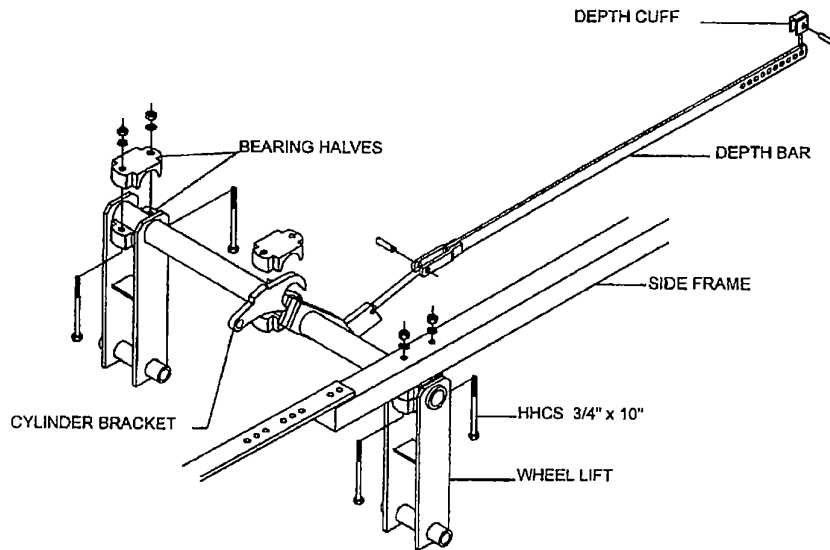

FIGURE 2 - WHEEL LIFT ASSEMBLY

nut. Insert another 3/4" x 6-1/2" bolt in front of each gang tube and secure with lockwasher and nut. Block gangs to prevent rolling.

Wheel Lift Assembly (Refer to Figure 2)

1) Remove wheel lift bolts and lift roll bearings from side frames and center frame. Raise wheel lift assembly to the frame making sure to have a bearing half positioned on the wheel lift below each frame member. Make sure grease fittings face to the front. Align the other bearing half and secure with 3/4" x 10" bolts and lockwashers and nuts.

2) Raise wheel lift and mount wheels to hubs. Lower wheel lift onto wheels.

3) Mount the body of the 4" x 8" wheel lift cylinder to the cylinder mount located on the center frame just behind the front cross frame. Loosen port plugs for movement of piston. Attach cylinder rod clevis to wheel lift using pin provided.

4) Slide depth control bar through the bracket at the rear of the center frame. Install the depth adjustment cuff behind the bracket. Attach the depth bar to the hydraulic cylinder bracket using the pin and two cotter pins provided.

Wing Assembly (Folding) (Refer to Fig. 3)

The rear wings have an extra disc 4" smaller than the discs on the front wings.

1) Attach the wing stop supports to the main frame disc gang tubes, short wing stops are for the rear gangs and long wing stops are for the front gangs, using a 1/2" x 7" bolt in the bottom hole and two 3/4" x 7" bolts in the upper holes with a spacer on the top bolt. Secure with lockwashers and nuts. Wing stops should be positioned according to the length of the wing gang tube.

2) Align the left rear wing (shown) with the hinge bracket on the main gang frame. Attach using a 1-3/4" x 7" pin with two roll pins.

3) Insert a 1-1/4" x 7" pin through 1-1/4" hole in wing and link assembly with flatwashers between wing and link assembly as shown. Insert roll pins with flatwashers on the outside against the wing.

4) Install wing fold latch with the angle side in toward the main frame and the notched side down. Install 1-1/8" x 9-7/8" pin through wing latch and main gang frame with flat washers on the outside of the latch. Install remaining

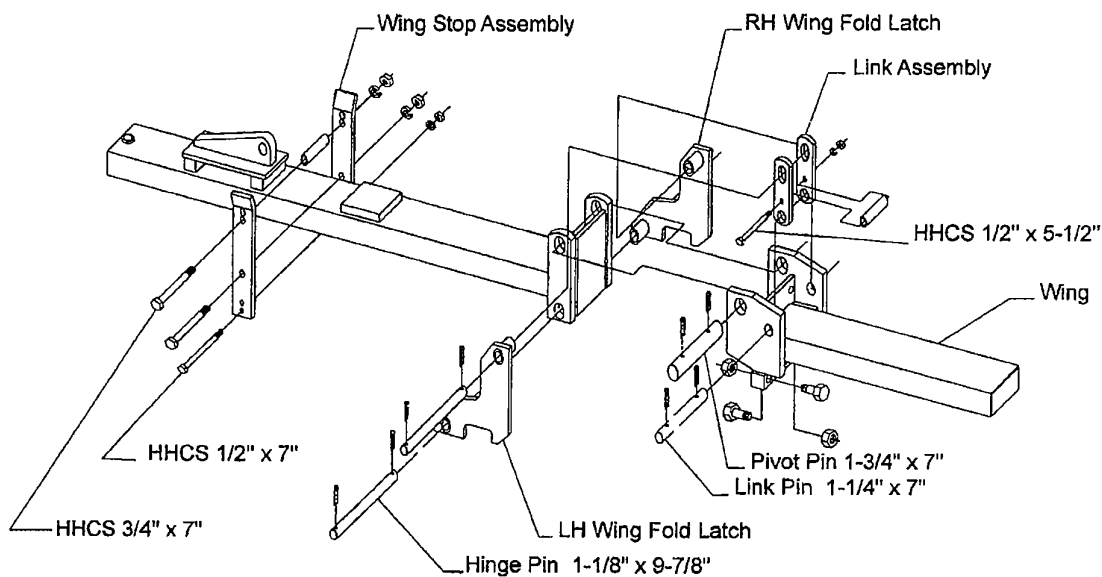

FIGURE 3 - WING HINGE ASSEMBLY

wing latch on other side of wing and secure both latches with roll pins.

5) Mount hydraulic cylinder (not shown) to main frame with two line ports facing front. Cylinder must be placed through wing support. Loosen port plugs to move piston out and align clevis with slotted holes in link assembly.

6) Insert pin in wing latch, through link assembly and cylinder clevis with flatwashers and roll pins.

7) Mount remaining wings in the same manner. For the front wings, mount cylinders with ports facing rear.

Tongue and Spring Rod Assembly (Refer to Figure 4)

1) Attach tongue to center frame using pins and cotter pins.

2) Install jack stand on tongue and use to support tongue.

3) Attach spring rod slide assembly to center frame with a 7/8" x 1-1/2" bolt and lockwasher on each side. Be sure holes in slide assembly and mounting plates align and that the bolt threads are fully engaged. Be sure the alemite in the slide assembly is up for easy access.

4) Mount spring rod assembly to tongue using pin and cotter pins.

Hydraulic Circuit Assembly (Refer to Fig. 5)

Each hose has only one swivel end so it is important to connect the end without the swivel first. Always tighten each hose end as it is connected before proceeding. Use a thread sealant on fittings to prevent leaking. **DO NOT OVER TIGHTEN.**

1) Run 180" hoses along tongue and up to 4" x 8" wheel lift cylinder. Remove port plugs from cylinder and thread 90° elbows into cylinder.

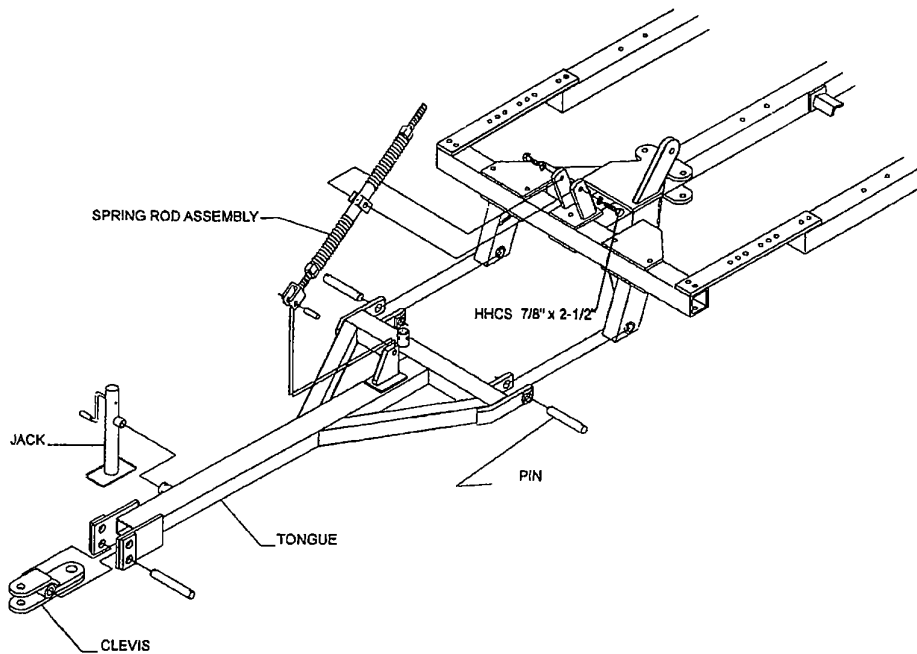

FIGURE 4 - HITCH ASSEMBLY

2) Thread hoses into elbows.

3) For folding units, thread a male tee into the line ports of the front wing cylinders. Wing cylinders should already have flow restrictors installed. If not, see your dealer about installing flow restrictors.

⚠ WARNING

DO NOT raise wings without flow restrictors. Wings will fall rapidly while lowering, and could cause serious injury or death.

4) Thread an elbow into each tee making sure the elbows are to the outside. Attach the proper hoses to the elbows.

5) Attach hoses from the front cylinder to corresponding ports in rear cylinders as shown.

6) From the left front cylinder, insert the proper hoses into the tee's to go toward center frame. Hoses should reach to the center frame.

7) Attach elbows, tees, and hoses to the right wing cylinders in the same manner as you did on the left wing.

8) Run 180" hoses up tongue to the tee on the center frame.

9) Secure all hoses with cable ties provided as shown.

BEFORE OPERATION

1) Tighten all loose hardware using the torque chart. **SEE ASSEMBLY**. Replace any missing hardware. On new machines, all hardware must be rechecked after first few hours of operation.

2) Replace any bent or broken parts.

3) Perform lubrication on implement as recommended. **SEE MAINTENANCE**.

4) Refer to your Tractor's Owner's Manual for recommended adjustments and weight distribution.

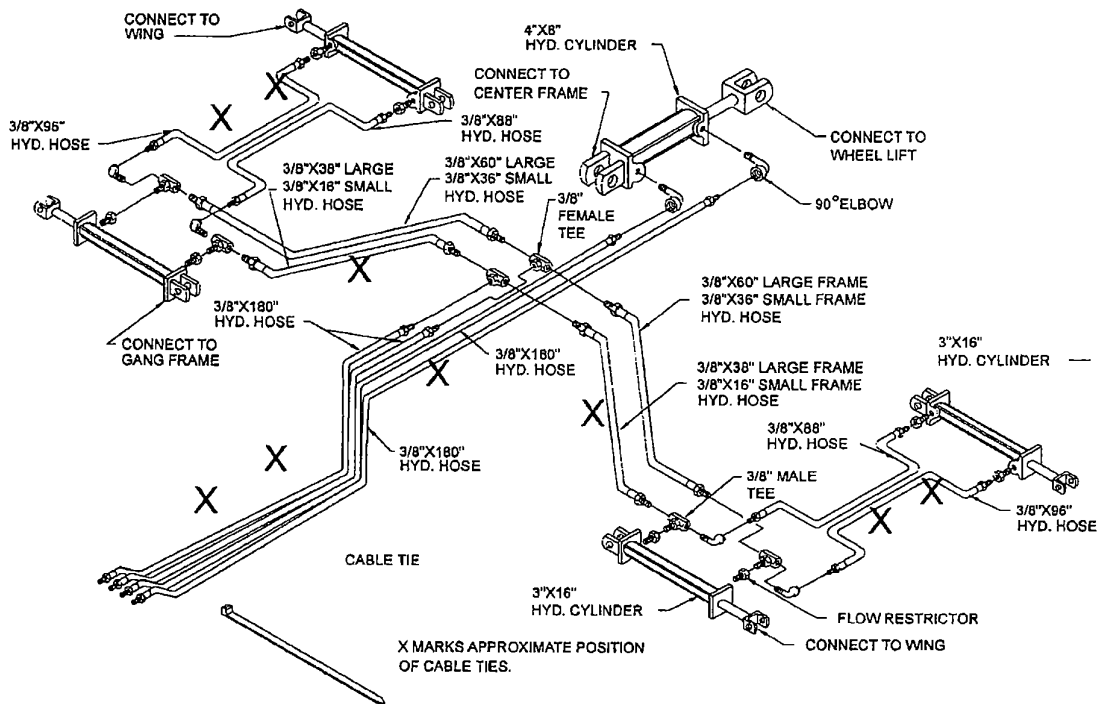

FIGURE 5 - HYDRAULIC CIRCUIT SMALL & LARGE FRAME MODELS

5) Inspect hydraulic lines and fittings for wear and leaks. Repair or replace if needed.

▲ WARNING

Check for small high pressure leaks by passing a piece of cardboard or wood over lines rather than hands. High pressure oil can penetrate skin and can only be removed surgically.

6) Read the **SAFETY** section of this manual to be sure of all precautions.

ATTACHING

▲ WARNING

Be sure bystanders are clear. Do not stand between implement and tractor. Shut off tractor and engage parking brake prior to dismounting.

- 1) Back tractor to align drawbar with clevis.
- 2) Attach hitch to drawbar with a suitable hitch pin and secure with a clip pin.
- 3) Attach hydraulic hoses to your tractor.

▲ WARNING

To help avoid injury from escaping hydraulic fluid under pressure, relieve the pressure in the system by shutting off tractor and moving remote cylinder operating levers in both directions before attaching to or detaching from the breakaway couplers.

OPERATION

First Time Out

- 1) Start tractor engine to perform hydraulic system check.

WARNING

Perform all tractor operations only while seated in the tractor seat. Do not stand beside tractor.

- 2) Watch fittings for leaks. If leaks are noticed, shut off tractor, relieve pressure from hydraulic lines, and make repairs before proceeding.
- 3) Check movement of wheel lift to be sure there is no interference.
- 4) Move wheel lift through full range of motion several times to purge air from system.
- 5) On folding units, slowly lift each wing to transport position.

WARNING

Be sure all bystanders are clear before lifting wings. Do not walk under raised wings for any reason.

- 6) Again check for leaks and make necessary repairs before proceeding.
- 7) Lift and lower wings several times to purge air from lines.
- 8) After hydraulic system is fully charged, check the level of the tractor's fluid reservoir and refill.

ADJUSTMENTS

Leveling

To level your harrow from front to rear, use the spring adjusting rod. Loosen the top nut so that no pressure is exerted on the top spring when the harrow is down and in its plowing position. With the top spring loose, tighten the bottom spring by screwing up on the nut located on the spring adjusting rod to increase cutting depth of the rear section. To decrease the cutting depth of the rear section, loosen the bottom spring by screwing down on the nut. After the cutting depth has been adjusted, lift the harrow to its transport position and tighten the top

spring by screwing down on the top nut until the harrow is approximately level.

Depth of Cut

The depth of cut is controlled by the use of the 4" x 8" lift cylinder or by use of the depth control bar. To adjust the depth of cut using the depth control bar, remove the pin and slide the depth adjustment cuff towards the front to decrease the depth of cut or slide it towards the rear to increase depth of cut. For a half hole adjustment, reverse the cuff without changing position.

Disc Angle

The disc angle is changed by removing the 3/4" x 6-1/2" bolt in front and the 3/4" x 6-1/2" bolt and gang stop behind each gang frame and shifting the outside ends of each gang frame forward or back until the desired angle is obtained. Reinsert the bolts and stops and tighten. Always have the same amount of angle in both front gang assemblies and the same amount of angle in both the rear gang assemblies.

Adjusting for Balk

Loosen the hardware holding front gangs to the gang tubes and slide the inside gangs inward until the butt plates are 1/2 inch from touching. Tighten gangs to tube making sure they are centered. Adjust remaining gangs in so that the correct disc spacing is maintained between the gangs. If this adjustment does not solve the problem, see about installing a balk breaker attachment.

Adjusting for Ridging or Furrowing

Loosen the hardware holding the rear gangs to the gang tube. Move all gang assemblies out if the harrow is leaving a ridge or move all gang assemblies in if the harrow is not covering the furrow left by the front gangs. Make sure all gangs are moved the same distance in relation to the center. Maintain proper disc spacing between adjacent gangs. Operating speed will affect these adjustments so make adjustments according to desired operating speed.

Wing Leveling and Lock (Folding Units)

Four bolts located on the under side of each wing are used to adjust the leveling and locking of the wings.

- 1) Adjust the two inside bolts in or out to level the wing frame with the main frame.
- 2) Adjust the two outside bolts in or out for proper locking of the wings. The wing latches should come down over the head of each bolt with minimum clearance.

TRANSPORTING

- 1) Lift harrow as high as possible. Move cuffs on depth bar as far forward as possible. Lower unit to rest on cuffs.
- 2) Fold wings up into wing stops on folding units.
- 3) Level harrow using top spring on spring rod. See leveling under **Adjustments**.
- 4) Transport at no more than 20 MPH. Use caution on rough terrain.
- 5) Check local laws governing transport of farm equipment on public roads.
- 6) Use caution and be aware of oncoming traffic and roadside obstructions.
- 7) Always use a slow moving vehicle (SMV) emblem. Mount it to the bracket on the rear cross frame.
- 8) **DO NOT** transport on public roads at night.

MAINTENANCE

Tightening Disk Axles

The disk axles are torqued at the factory and do not require further tightening before use. After the first few hours of operation, the gang components will "seat" themselves which tends to loosen the axles. After this initial run-in period, the disk axle should be checked and retorqued if necessary. Torque 1 1/8" axles to 500 ft.--lbs.

To check the tightness of the gang axle, raise the unit off the ground, and strike each blade lightly with a hammer. If a flat sound is heard, the blade is loose and the gang axle must be retorqued. A ringing sound indicates the blade is tight.

After this check, the axles should not require tightening unless the axle nut is removed.

Wheel Hubs

After initial use check wheel hubs for excessive play on spindle. If necessary tighten bearing adjustment nut to eliminate lateral movement on spindle while still allowing hub rotation.

Before Each Use

- 1) Check tires for proper inflation.
- 2) Check over entire implement for missing or worn parts. Make necessary repairs before going to the field.
- 3) Check to see that all hardware is in place and tight.
- 4) Check disc gangs to see that they rotate freely.
- 5) Perform lubrication as described in "**LUBRICATION**".
- 6) Check hydraulic system for leaks. Check lines for high pressure pinhole leaks by passing an object over the lines.

WARNING

CAUTION: Do not use bare hand to check for leaks. Hydraulic fluid under high pressure can penetrate skin and cause poisoning.

Lubrication Schedule

- 1) Apply grease to the following lubrication points before each use. Be sure to clean grease fittings before applying grease.

- wing hinges





- spring rods
- wheel axle couplers
- disc gang bearings
- wheel lift bearings

2) Clean wheel hubs at the end of each season. Repack with grease and assemble. Be sure to tighten bearing adjustment nut so hub turns freely without lateral movement on spindle.

STORAGE

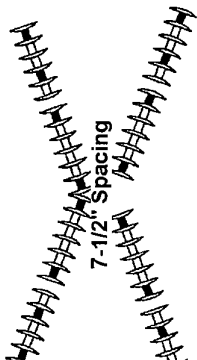
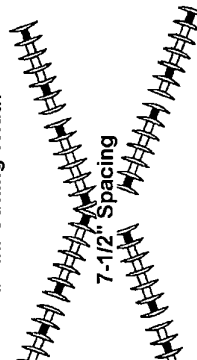
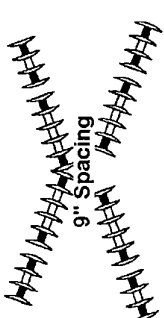
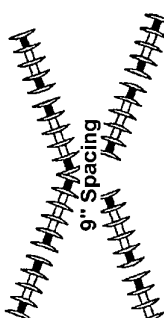

- 1) Store unit under shelter from weather.
- 2) With wings locked in storage position, lower harrow to relieve weight from transport cylinders.
- 3) Support tongue with stand to relieve weight from drawbar.
- 4) Relieve pressure from hydraulic lines before disconnecting from tractor.
- 5) For periods of long storage, coat disk blades and other soil engaging surfaces with oil to prevent rusting.
- 6) Coat exposed portion of hydraulic cylinder rods with grease to prevent rusting.

GANG LAYOUTS 350 NARROW FRAME

<p>15ft. 1in. Cutting Width</p>  <p>7-1/2" Spacing</p> <p>350-S-48-77 / 350-F-48-77</p>	<p>16ft. 3in. Cutting Width</p>  <p>7-1/2" Spacing</p> <p>350-S-52-77 / 350-F-52-77</p>	<p>17ft. 5in. Cutting Width</p>  <p>7-1/2" Spacing</p> <p>350-S-56-77 / 350-F-56-77</p>
<p>14ft. 10in. Cutting Width</p>  <p>9" Spacing</p> <p>350-S-40-99 / 350-F-40-99</p>	<p>16ft. 3in. Cutting Width</p>  <p>9" Spacing</p> <p>350-S-44-99 / 350-F-44-99</p>	<p>17ft. 8in. Cutting Width</p>  <p>9" Spacing</p> <p>350-S-48-99 / 350-F-48-99</p>
<p>15ft. 1in. Cutting Width</p>  <p>9" F - 7-1/2" R Spacing</p> <p>350-S-44-97 / 350-F-44-97</p>	<p>16ft. 3in. Cutting Width</p>  <p>9" F - 7-1/2" R Spacing</p> <p>350-S-48-97 / 350-F-48-97</p>	<p>17ft. 5in. Cutting Width</p>  <p>9" F - 7-1/2" R Spacing</p> <p>350-S-52-97 / 350-F-52-97</p>



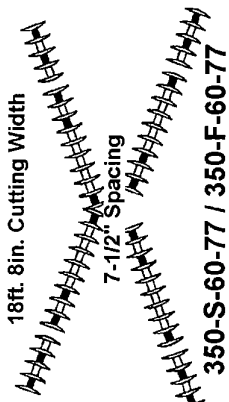
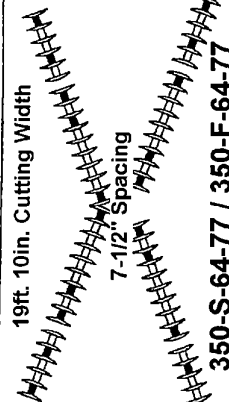
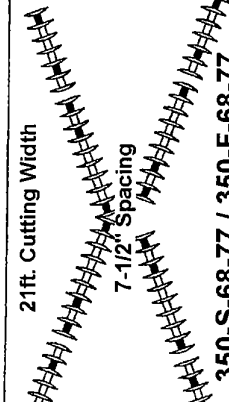
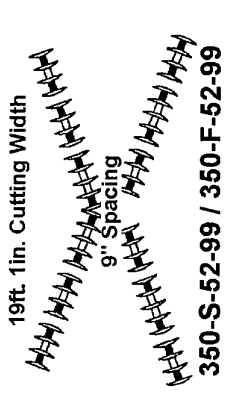
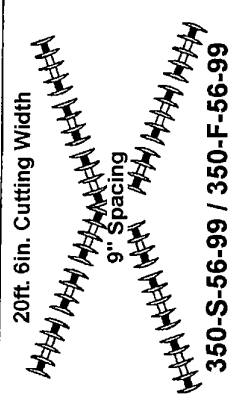
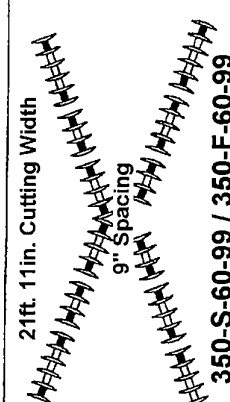

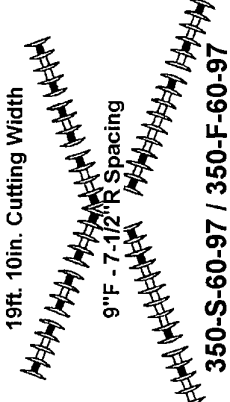
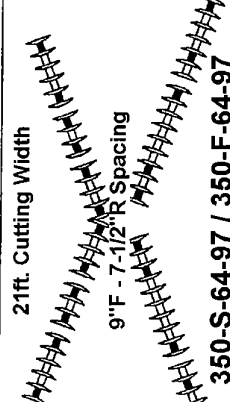

Models 350-S Have RIGID Brg. Hangers
Models 350-F Have SPRING Brg. Hangers

GANG LAYOUTS 350 WIDE FRAME

<p>18ft. 8in. Cutting Width 7-1/2" Spacing 350-S-60-77 / 350-F-60-77</p> 	<p>19ft. 10in. Cutting Width 7-1/2" Spacing 350-S-64-77 / 350-F-64-77</p> 	<p>21ft. Cutting Width 7-1/2" Spacing 350-S-68-77 / 350-F-68-77</p> 
<p>19ft. 1in. Cutting Width 9" Spacing 350-S-52-99 / 350-F-52-99</p> 	<p>20ft. 6in. Cutting Width 9" Spacing 350-S-56-99 / 350-F-56-99</p> 	<p>21ft. 11in. Cutting Width 9" Spacing 350-S-60-99 / 350-F-60-99</p> 
<p>18ft. 8in. Cutting Width 9" F - 7-1/2" R Spacing 350-S-56-97 / 350-F-56-97</p> 	<p>19ft. 10in. Cutting Width 9" F - 7-1/2" R Spacing 350-S-60-97 / 350-F-60-97</p> 	<p>21ft. Cutting Width 9" F - 7-1/2" R Spacing 350-S-64-97 / 350-F-64-97</p> 

Models 350-S Have RIGID Brg. Hangers
Models 350-F Have SPRING Brg. Hangers



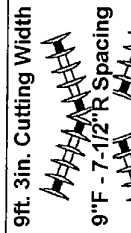
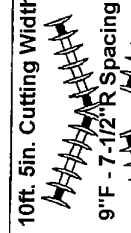
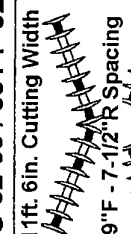



GANG LAYOUTS 351 NARROW FRAME

<p>9ft. 3in. Cutting Width  7-1/2" Spacing 351-S-28-77 / 351-F-28-77</p>	<p>10ft. 5in. Cutting Width  7-1/2" Spacing 351-S-32-77 / 351-F-32-77</p>	<p>11ft. 6in. Cutting Width  7-1/2" Spacing 351-S-36-77 / 351-F-32-77</p>	
<p>9ft. 4in. Cutting Width  9" Spacing 351-S-24-99 / 351-F-24-99</p>	<p>10ft. 9in. Cutting Width  9" Spacing 351-S-28-99 / 351-F-28-99</p>	<p>12ft. 2in. Cutting Width  9" Spacing 351-S-32-99 / 351-F-32-99</p>	
<p>9ft. 3in. Cutting Width  9" F - 7-1/2" R Spacing 351-S-26-97 / 351-F-26-97</p>	<p>10ft. 5in. Cutting Width  9" F - 7-1/2" R Spacing 351-S-30-97 / 351-F-30-97</p>	<p>11ft. 6in. Cutting Width  9" F - 7-1/2" R Spacing 351-S-34-97 / 351-F-34-97</p>	

Models 351-S Have RIGID Brg. Hangers

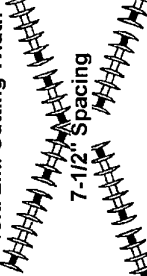
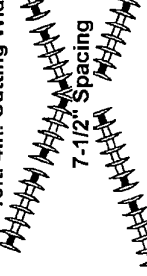
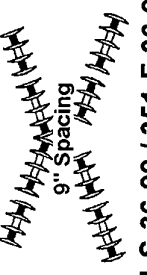
Models 351-F Have SPRING Brg. Hangers

GANG LAYOUTS 351 WIDE FRAME

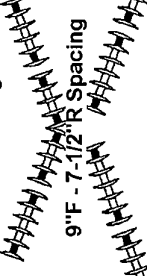
<p>12ft. 10in. Cutting Width  7-1/2" Spacing 351-S-40-77 / 351-F-40-77</p>	<p>14ft. Cutting Width  7-1/2" Spacing 351-S-44-77 / 351-F-44-77</p>	<p>15ft. 2in. Cutting Width  7-1/2" Spacing 351-S-48-77 / 351-F-48-77</p>	<p>16ft. 4in. Cutting Width  7-1/2" Spacing 351-S-52-77 / 351-F-52-77</p>
<p>13ft. 7in. Cutting Width  9" Spacing 351-S-36-99 / 351-F-36-99</p>	<p>14ft. 10in. Cutting Width  9" Spacing 351-S-40-99 / 351-F-40-99</p>	<p>16ft. 3in. Cutting Width  9" Spacing 351-S-44-99 / 351-F-44-99</p>	
<p>14ft. Cutting Width  9" F - 7-1/2" R Spacing 351-S-40-97 / 351-F-40-97</p>	<p>15ft. 2in. Cutting Width  9" F - 7-1/2" R Spacing 351-S-44-97 / 351-F-44-97</p>	<p>16ft. 4in. Cutting Width  9" F - 7-1/2" R Spacing 351-S-48-77 / 351-F-48-77</p>	

Models 351-S Have RIGID Brg. Hangers
 Models 351-F Have SPRING Brg. Hangers

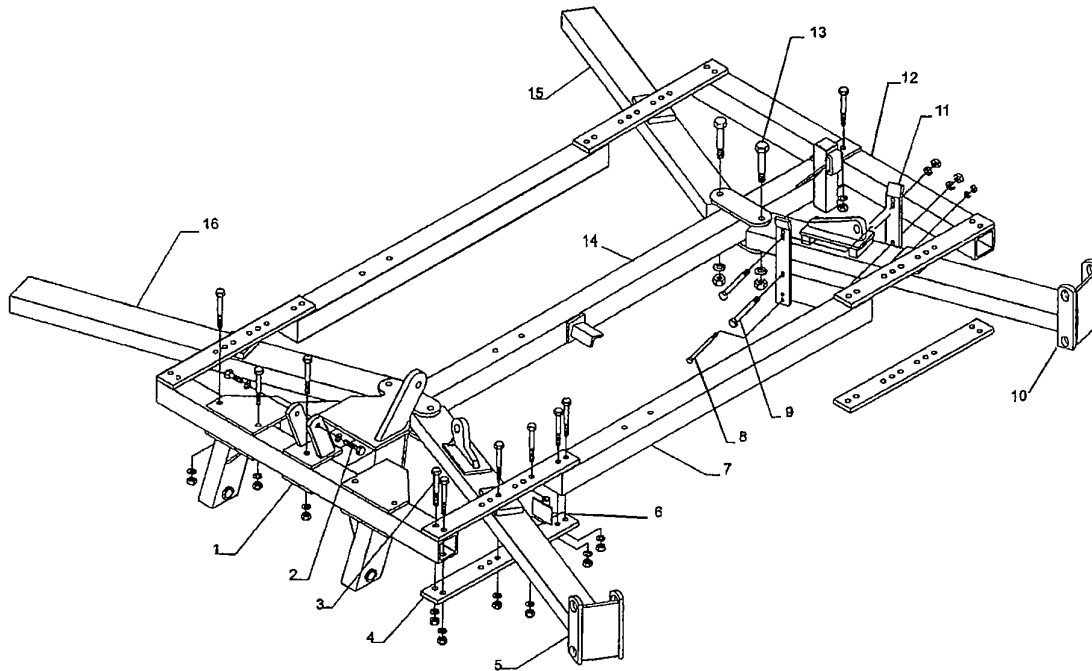

FIGURE 6 - SMALL & LARGE FRAME COMPONENTS

Item	Part #	Description	Qty	Item	Part #	Description	Qty	
1	812265	FRONT TUBE--NARROW	1		812482	9&10 DISC RRGANG FRM	2	
	812368	FRONT TUBE--WIDE	1		11	046525	WING STOP --15" LONG	8
2	203748	SHOULDER BOLT 7/8"	2		212032	WING STOP-- 21-1/2" LONG	8	
	303958	WASHER/LOCK 7/8"	2	12	812263	REAR TUBE --NARROW	1	
3	303710	HHCS 3/4" X 6-1/2"	30			812370	REAR TUBE ---WIDE	1
	303957	WASHER/LOCK 3/4"	30	13	303737	HHCS 7/8" X 6-1/2"	4	
	304009	NUT/HEX 3/4" NC	30			303958	WASHER/LOCK 7/8"	4
4	812267	ADJ. PLATE --NAR FRAME	4			304010	NUT/HEX 7/8" NC	4
	812634	ADJ. PLATE --WIDE FRAME	4	14	812269	CNTR FRAME ---NARROW	1	
5	812479	6&7 DISC FRT GANG FRM	2			812359	CNTR FRAME ---WIDE	1
		812481	9&10 DISC FRT GANG FRM	2	15	812293	GANG TUBE 79"-- NARROW	2
6	812287	STOP ASSEMBLY	4			812381	GANG TUBE 60" --NARROW	2
	7	812266	SIDE FRAME--- NARROW	2			812382	GANG TUBE 69"-- NARROW
		812363	SIDE FRAME ---WIDE	2			812384	GANG TUBE 88" --WIDE
8	303665	HHCS 1/2" X 7"	4			812385	GANG TUBE 97" --WIDE	2
	303955	WASHER/LOCK 1/2"	4			812386	GANG TUBE 106" --WIDE	2
	304007	NUT/HEX 1/2" NC	4	16		812380	GANG TUBE 51" --NARROW	2
9	303711	HHCS 3/4" X 7"	8				812381	GANG TUBE 60" --NARROW
	303957	WASHER/LOCK 3/4"	8			812382	GANG TUBE 69" --NARROW	2
	304009	NUT/HEX 3/4" NC				812383	GANG TUBE 79" --WIDE	2
	812733	SPACER	4			812384	GANG TUBE 88" --WIDE	2
10	812480	6&7 DISC RR GANG FRAME	2		812385	GANG TUBE 97" --WIDE	2	

HITCH COMPONENTS			
Item	Part #	Description	Qty
1	209013	CLEVIS--SINGLE OR DBL	1
2	209186	CLEVIS PIN 1-3/8" X 9"	1
	304151	PIN/COTTER 3/8" X 2"	2
3	812255	TONGUE	1
4	209125	HINGE PIN 1-3/8" X 8"	2
	304151	PIN/COTTER 3/8" X 2"	4
5	203100	SPRING ROD PIN 7/8" X 3-3/8"	1
	304137	PIN/COTTER 5/16" X 1-1/2"	2
6	209603	SPRING ROD ASSEMBLY	1
7	304053	NUT/HEX HEAVY 1-3/8"	1
8	205163	WASHER/ FLAT SPECIAL	2
9	207894	SPRING-COMPRESSION	2
10	203742	SLIDE ASSEMBLY	1
	304194	ALEMITE	1
11	206553	HOSE HOLDER	1
	303651	HHCS 1/2" X 1-1/2"	1
	303955	WASHER/LOCK 1/2"	1
	303971	WASHER/FLAT 1/2"	1
	304020	NUT/HEX LOCK 1/2" NC	1
12	808026	JACK	1

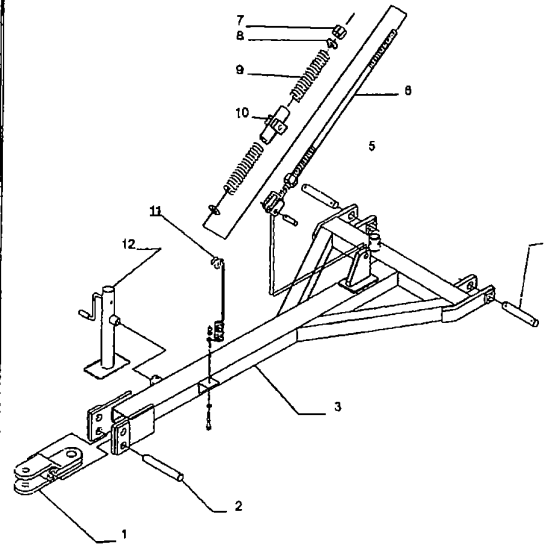

FIGURE 7 - HITCH COMPONENTS

WING HINGE COMPONENTS			
Item	Part #	Description	Qty
1	812462	HINGE PIN 1-1/8" X 10-7/8"	2
	303976	WASHER/FLAT 1-1/8"	4
	304260	PIN/ROLL 3/8" X 2"	4
2	812731	LH WING FOLD LATCH	1
3	812463	LINK PIN 1-1/4" X 8"	1
	303976	WASHER/FLAT 1-1/8"	2
	304260	PIN/ROLL 3/8" X 2"	2
4	812464	PIVOT PIN 1-3/4" X 8"	1
	304260	PIN/ROLL 3/8" X 2"	2
5	303726	HHCS 7/8" X 2"	2
6	303728	HHCS 7/8" X 2-1/2"	2
7	812487	4 DISC WING FRAME	1
	812488	5 DISC WING FRAME	1
	812489	6 DISC WING FRAME	1
8	303662	HHCS 1/2" X 5-1/2"	1
9	812470	BUSHING 7/8" OD X 3-3/8"	1
10	046536	LINK	2
11	812730	RH WING FOLD LATCH	1

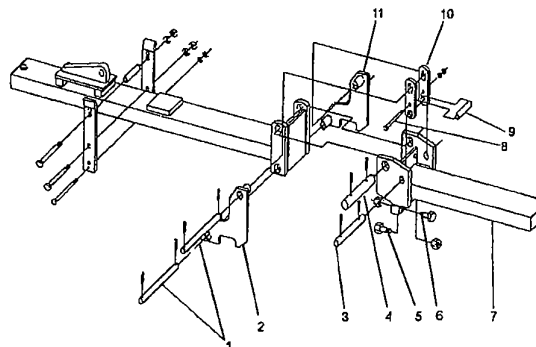

FIGURE 8 - WING HINGE COMPONENTS

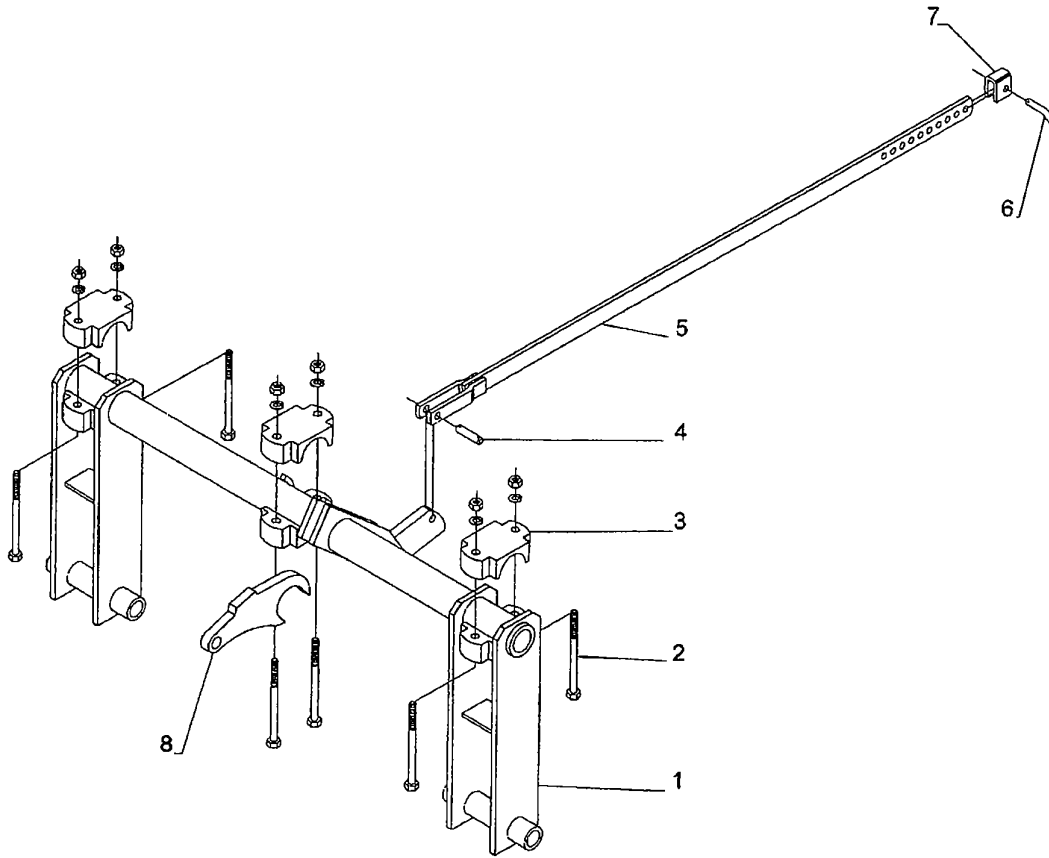

FIGURE 10 - LARGE AND SMALL FRAME WHEEL LIFT COMPONENTS

Item	Part #	Description	Qty
1	812284	WHEEL LIFT--NARROW FRAME	1
	812365	WHEEL LIFT--WIDE FRAME	1
2	303717	HHCS 3/4" X 10"	6
	303957	WASHER/LOCK 3/4"	6
3	304009	NUT/HEX 3/4"	6
	207010	BEARING HALF W/ALEMITE	6
4	304194	ALEMITE	6
	204758	DEPTH BAR PIN 3/4" X 3-1/4"	1
5	304137	PIN/COTTER 5/16" X 1-1/2"	2
	207564	DEPTH BAR--NARROW FRAME 69-1/4"	1
6	812496	DEPTH BAR--WIDE FRAME 74-1/4"	1
	209938	DEPTH PIN-BENT 5/8" DIAMETER	1
7	304244	HAIRPIN COTTER 3/16	1
	204683	DEPTH CUFF	1
8	813469	HYDRAULIC CYLINDER BRACKET	1
	208863	BUSHING/TENSION 1-1/4 OD X 1 ID	1

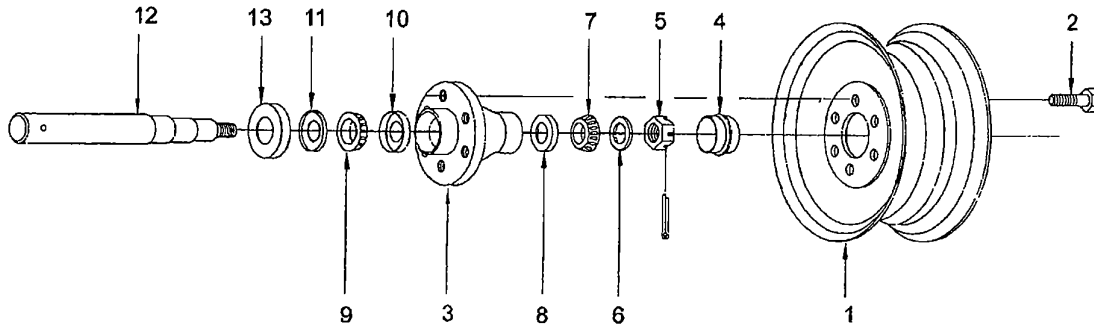

FIGURE 11 - WHEEL HUB COMPONENTS

FIGURE 11 - WHEEL COMPONENTS			
Item	Part	Description	Qty
1	208861	RIM/15" x 8" - 6 BOLT	
	208634	RIM/15" x 6" - 6 BOLT	
2	403817	LUG BOLT - 1/2"-20UNF X 1-1/2"	6
3	204515	WHEEL HUB WITH CUPS (INCL. 8 & 10)	1
4	204523	HUB CAP	1
5	304037	NUT/HEX SLOTTED 7/8"	1
	304094	PIN/COTTER 5/32" X 1-1/4"	1
6	211422	FLAT WASHER	1
7	204524	BEARING CONE - 14137A	1
8	203021	BEARING CUP - 14276	1
9	204526	BEARING CONE - 342A	1
10	204525	BEARING CUP - 332	1
11	204527	GREASE SEAL - CR 18823	1
12	210685	WHEEL SPINDLE	1
	303658	HHCS 1/2" X 3-1/2"	1
	303955	WASHER/LOCK 1/2"	1
	304007	NUT/HEX 1/2" NC	1
13	204520	DUST COLLAR	1
	207889	COMPLETE HUB ASSEMBLY (INCL. 2-11 & 13)	-
	207937	BEARING KIT (INCL. 7-11)	-

STANDARD RIGID & SPRING BEARING HANGER COMPONENTS

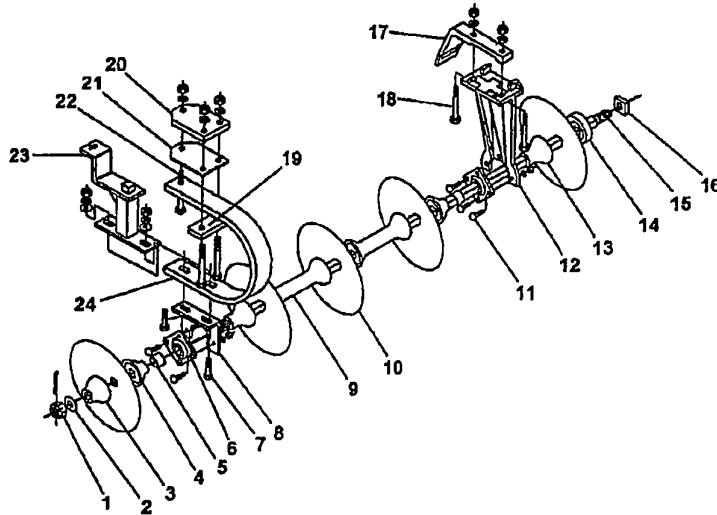

FIGURE 11 - DISC GANG COMPONENTS

Item	Part #	Description
1	304039 304111	SLOTTED HEX NUT 1-1/8" COTTER PIN 3/16" X 2"
2	303976	FLATWASHER 1-1/8"
3	204704	END WASHER
4	205486	CONCAVE SPACER 2-13/16" Long
5	807110	SPACER 1-5/16" Long for 9" Sp.
6	811197	BEARING DHU 1-1/8" S209
7	303680 303956 303972 304008	HHCS 5/8" X 3" - NC Gr.5 5/8" LOCK WASHER 5/8" FLAT WASHER 5/8" HEX NUT - NC
8	808755	BRG. BRACKET for Spring Hanger
9	205486 205488 207344	CONCAVE SPACER for 7-1/2" CONVEX SPACER for 7-1/2" DOUBLE END SPACER for 9" Sp.
10	-----	DISC BLADES SEE Page 27
11	303859 303955 304007	CARRIAGE BOLT 1/2 X 1-1/2" Gr.5 1/2" LOCK WASHER 1/2" HEX NUT - NC
12	807873	RIGID BRG. HANGER
13	205489	CONVEX SPACER 3-5/16" Long
14	206613	BUTT PLATE

Item	Part #	Description
15	207038 207039 206618 208325 208326 206626 206627 206618 208131 807121	AXLE 5-D - 7-1/2" Sp. AXLE 6-D - 7-1/2" Sp. AXLE 7-D - 7-1/2" Sp. AXLE 8-D - 7-1/2" Sp. AXLE 9-D - 7-1/2" Sp. AXLE 4-D - 9" Sp. AXLE 5-D - 9" Sp. AXLE 6-D - 9" Sp. AXLE 7-D - 9" Sp. AXLE 8-D - 9" Sp.
16	208931	SQUARE NUT 1-1/8" - NC
17	807874	TOP STRAP for Rigid Hanger
18	303708 303957 304009	HHCS 3/4" X 5-1/2" - NC Gr.5 3/4" LOCK WASHER 3/4" HEX NUT - NC
19	813106 303711 303957 304009	STRAP HHCS 3/4" X 7" - NC Gr.5 3/4" LOCK WASHER 3/4" HEX NUT
20	207823	TOP PLATE
21	208468	LOWER PLATE
22	303709 303957 304009	HHCS 3/4" X 6" - NC Gr.5 3/4" LOCK WASHER 3/4" HEX NUT
23	808309	SRAPER BAR BRKT. Spring Hgr.
24	207664	SPRING BEARING HANGER

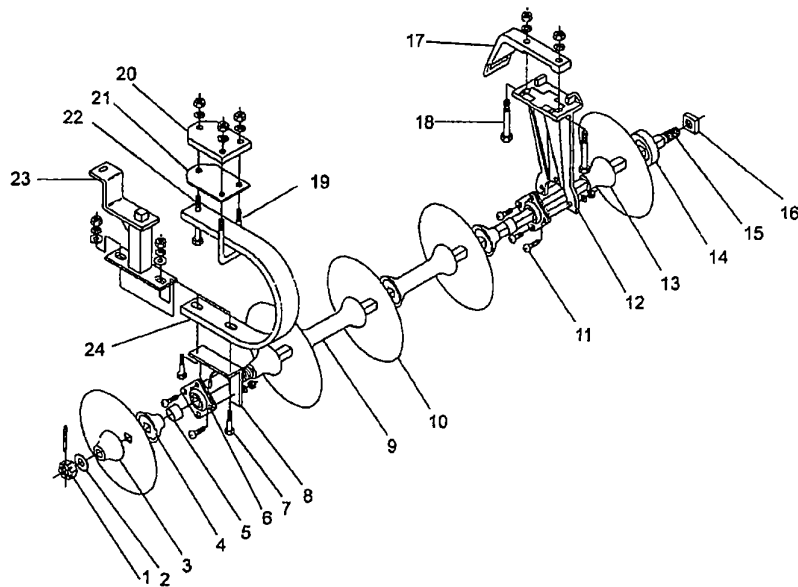

FIGURE 11 - DISC GANG COMPONENTS

Item	Part #	Description	Qty	Item	Part #	Description	Qty
1	304039	NUT/HEX SLOTTED 1-1/8"	1	16	208325	AXLE -8 DISC 7-1/2" SP.	1
	304111	PIN/COTTER 3/16" X 2"	1		208326	AXLE -9 DISC 7-1/2" SP.	1
2	303976	WASHER/FLAT 1-1/8"	1		206626	AXLE -4 DISC 9" SP.	1
3	204704	END WASHER	1		206627	AXLE -5 DISC 9" SP.	1
4	205486	SPACER/CONCAVE	2		206618	AXLE -6 DISC 9" SP.	1
5	807110	SPACER 1-5/16" LG. 9" SP.	2		208131	AXLE -7 DISC 9" SP.	1
6	811197	BEARING DHU 1-1/8" S209	2		807121	AXLE -8 DISC 9" SP.	1
7	303680	HHCS 5/8" x 3"	4		17	208931	NUT/SQ 1-1/8"
	303956	WASHER/LOCK 5/8"	4	807874	TOP STRAP/DELTA	2	
	303972	WASHER/FLAT 5/8"	4	18	303708	HHCS 3/4" X 5-1/2"	4
	304008	NUT/HEX 5/8" NC	4	303957	WASHER/LOCK 3/4"	4	
8	808755	BEARING BRACKET SPRING	2	304009	NUT/HEX 3/4"	4	
9	205486	SPACER/CONCAVE 7-1/2"	-	19	207845	3/4" U-BOLT	2
	205488	SPACER/CONVEX 7-1/2"	-	303957	WASHER/LOCK 3/4	4	
	207344	SPACER/FULL 9" SP.	-	304009	NUT/HEX 3/4"	4	
10	TABLE 1	DISC BLADES	-	20	207823	TOP PLATE	2
	303859	BOLT/CARR 1/2" x 1-1/2"	6	21	208468	LOWER PLATE	2
11	303955	WASHER/LOCK 1/2"	6	303709	HHCS 3/4" X 6"	2	
	304007	NUT/HEX 1/2" NC	6	22	303957	WASHER/LOCK 3/4	2
12	807873	HANGER/DELTA BEARING	2	304009	NUT/HEX 3/4"	2	
13	205489	SPACER/CONVEX	2	23	808309	SPRING SCRAPER BRKT	2
14	206613	BUTT PLATE	1	24	207664	SPRING BEARING HANGER	2
15	207038	AXLE -5 DISC 7-1/2" SP.	1				
	207039	AXLE -6 DISC 7-1/2" SP.	1				
	206618	AXLE -7 DISC 7-1/2" SP.	1				

TABLE 1 DISC BLADES	
Part #	Description
208439	16" ROUND
205003	18" ROUND
204004	20" ROUND
204010	22" ROUND
205020	22" ROUND HEAVY DUTY
208440	16" CUT OUT
205002	18" CUT OUT
204003	20" CUT OUT
204005	22" CUT OUT
205005	22" CUT OUT HEAVY DUTY

INSTRUCTIONS FOR ORDERING DISC BLADES

When ordering blades, remember that the outside rear blades get two "taper" blades each and the outside front gangs get one taper blade each. Blades are tapered in 2" diameter increments.

- 1) Determine the total number of blades for the unit regardless of size.
- 2) For the main disc size, order six (6) LESS than the total number found in step 1.
- 3) Order four (4) blades 2" smaller in diameter than the main disc size. These are taper blades for the outside front and rear gangs.
- 4) Order two (2) blades 4" smaller in diameter than the main disc size. These are outside taper blades for the rear gangs.

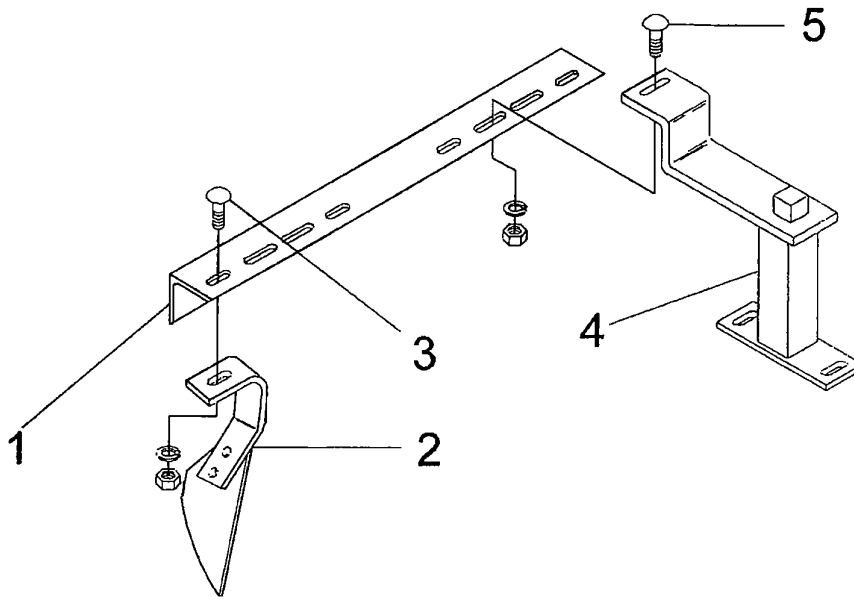

FIGURE 12 - SPRING SCRAPER COMPONENTS

Item	Part #	Description
1	see TABLE 2 Page 30	SCRAPER BAR
2	807098	LEFT FRONT OR RIGHT REAR SCRAPER ASSEMBLY
	807099	RIGHT FRONT OR LEFT REAR SCRAPER ASSEMBLY
3	303859	BOLT/CARR 1/2" X 1-1/2"
	303955	WASHER/LOCK 1/2"
	303971	WASHER/FLAT 1/2"
	304007	NUT/HEX 1/2" NC
4	808309	SPRING SCRAPER BRACKET
5	303861	BOLT/CARR 1/2" X 2"
	303955	WASHER/LOCK 1/2"
	303971	WASHER/FLAT 1/2"
	304007	NUT/HEX 1/2" NC

NOTE: When ordering scraper components, LEFT refers to left front or right rear and RIGHT refers to right front or left rear disc gang on the implement. LEFT and RIGHT are determined by standing at the rear of the implement and facing it.

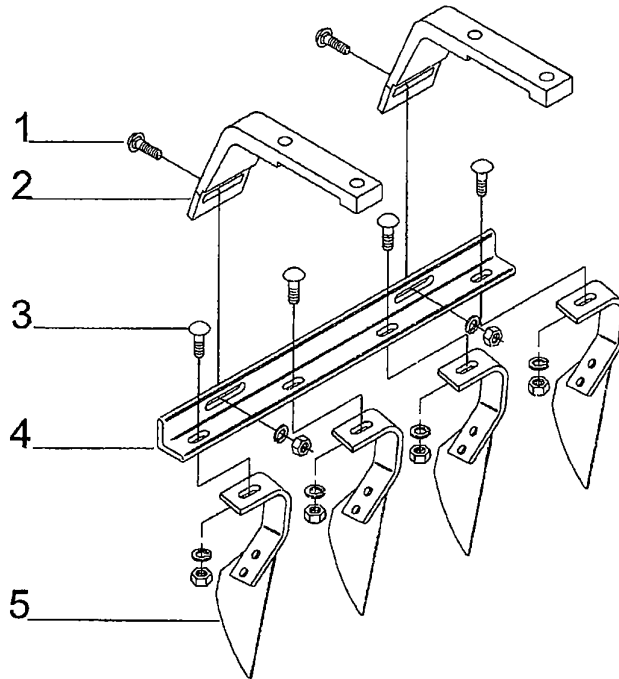

FIGURE 13 - RIGID SCRAPER COMPONENTS

Item	Part #	Description
1	303860	BOLT/CARR 1/2" X 1-3/4"
	303955	WASHER/LOCK 1/2"
	303971	WASHER/FLAT 1/2"
	304007	NUT/HEX 1/2" NC
2	807874	TOP STRAP CASTING
3	303859	BOLT/CARR 1/2" X 1-1/2"
	303955	WASHER/LOCK 1/2"
	303971	WASHER/FLAT 1/2"
	304007	NUT/HEX 1/2" NC
4	see TABLE 3 page 30	SCRAPER BAR
5	807098	LEFT FRONT OR RIGHT REAR SCRAPER ASSEMBLY
	807099	RIGHT FRONT OR LEFT REAR SCRAPER ASSEMBLY

NOTE: When ordering scraper components, **LEFT** refers to left front or right rear and **RIGHT** refers to right front or left rear disc gang on the implement. **LEFT** and **RIGHT** are determined by standing at the rear of the implement and facing it.

Item 1	Description	Length
808263	4 DISC 3 SCRAPER 7-1/2" SPACING	21-1/2"
808261	4 DISC 4 SCRAPER 7-1/2" SPACING	25-1/2"
808264	5 DISC 4 SCRAPER 7-1/2" SPACING	29"
808262	5 DISC 5 SCRAPER 7-1/2" SPACING	33"
808265	6 DISC 5 SCRAPER 7-1/2" SPACING	36-1/2"
812809	6 DISC 6 SCRAPER 7-1/2" SPACING	40-1/2"
808266	7 DISC 6 SCRAPER 7-1/2" SPACING	44"
812810	7 DISC 7 SCRAPER 7-1/2" SPACING	48"
808267	8 DISC 7 SCRAPER 7-1/2" SPACING	51-1/2"
813432	10 DISC 9 SCRAPER 7-1/2" SPACING	66-1/2"
813431	10 DISC 10 SCRAPER 7-1/2" SPACING	70-1/2"
805018	4 DISC 3 SCRAPER 9" SPACING	24-3/4"
805015	4 DISC 4 SCRAPER 9" SPACING	30"
805019	5 DISC 4 SCRAPER 9" SPACING	33-3/4"
805016	5 DISC 5 SCRAPER 9" SPACING	39"
805020	6 DISC 5 SCRAPER 9" SPACING	42-3/4"
805017	6 DISC 6 SCRAPER 9" SPACING	48"
805021	7 DISC 6 SCRAPER 9" SPACING	51-3/4"
805349	7 DISC 7 SCRAPER 9" SPACING	57"
808260	8 DISC 7 SCRAPER 9" SPACING	60-3/4"

Left Hand	Right Hand	Disc Gang Used On	Length
812554	812555	4 DISC 3 SCRAPER 7-1/2" SPACING	22"
812387	812388	5 DISC 4 SCRAPER 7-1/2" SPACING	29-1/2"
812389	812390	5 DISC 5 SCRAPER 7-1/2" SPACING	34"
812391	812392	6 DISC 5 SCRAPER 7-1/2" SPACING	37"
812393	812394	6 DISC 6 SCRAPER 7-1/2" SPACING	41-1/2"
812395	812396	7 DISC 6 SCRAPER 7-1/2" SPACING	44-1/2"
812397	812398	7 DISC 7 SCRAPER 7-1/2" SPACING	49"
812399	812400	8 DISC 7 SCRAPER 7-1/2" SPACING	52"
812401	812402	8 DISC 8 SCRAPER 7-1/2" SPACING	56-1/2"
812403	812404	9 DISC 8 SCRAPER 7-1/2" SPACING	59-1/2"
812407	812408	10 DISC 9 SCRAPER 7-1/2" SPACING	67"
812409	812410	10 DISC 10 SCRAPER 7-1/2" SPACING	71-1/2"
807277	807278	4 DISC 3 SCRAPER 9" SPACING	25"
807273	807274	4 DISC 4 SCRAPER 9" SPACING	31"
807165	807166	5 DISC 4 SCRAPER 9" SPACING	34"
807275	807276	5 DISC 5 SCRAPER 9" SPACING	40"
807167	807168	6 DISC 5 SCRAPER 9" SPACING	43"
807153	807154	6 DISC 6 SCRAPER 9" SPACING	49"
807169	807170	7 DISC 6 SCRAPER 9" SPACING	52"
807171	807172	8 DISC 7 SCRAPER 9" SPACING	61"

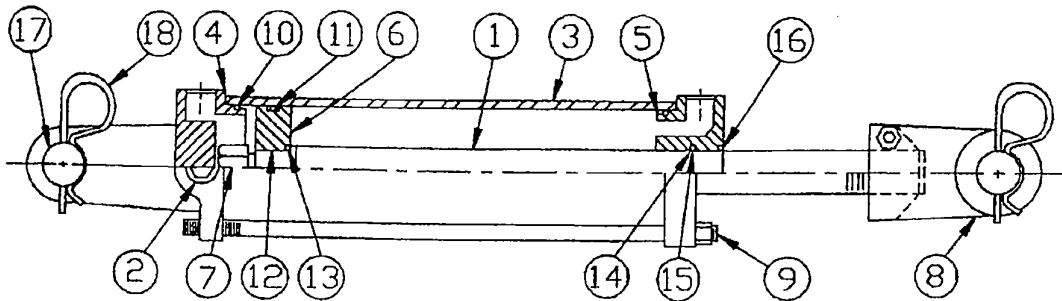

Fig.15 Hydraulic cylinder components

Item	part no. 4x8	part no. 2½x16	description	qty.
1	209230	208601	piston rod	1
2	208602	208602	pipe plug	2
3	209231	208603	tube	1
4	208846	208604	butt	1
5	208847	208605	gland	1
6	208848	208606	piston	1
7	208849	208607	locknut	1
8	208850	208493	clevis assembly	1
9	209232	208608	tie rod	4
10	**	**	O-ring	2
11	**	**	O-ring	1
12	**	**	Bu-washer	2
13	**	**	O-ring	1
14	**	**	O-ring	1
15	**	**	Bu-washer	1
16	**	**	wiper	1
**	208860	208618	seal kit includes items 10-16	1
17	208859	208616	clevis pin	2
18	208617	208617	hair pin clip	4
NI	209134	208546	hydraulic cylinder complete	

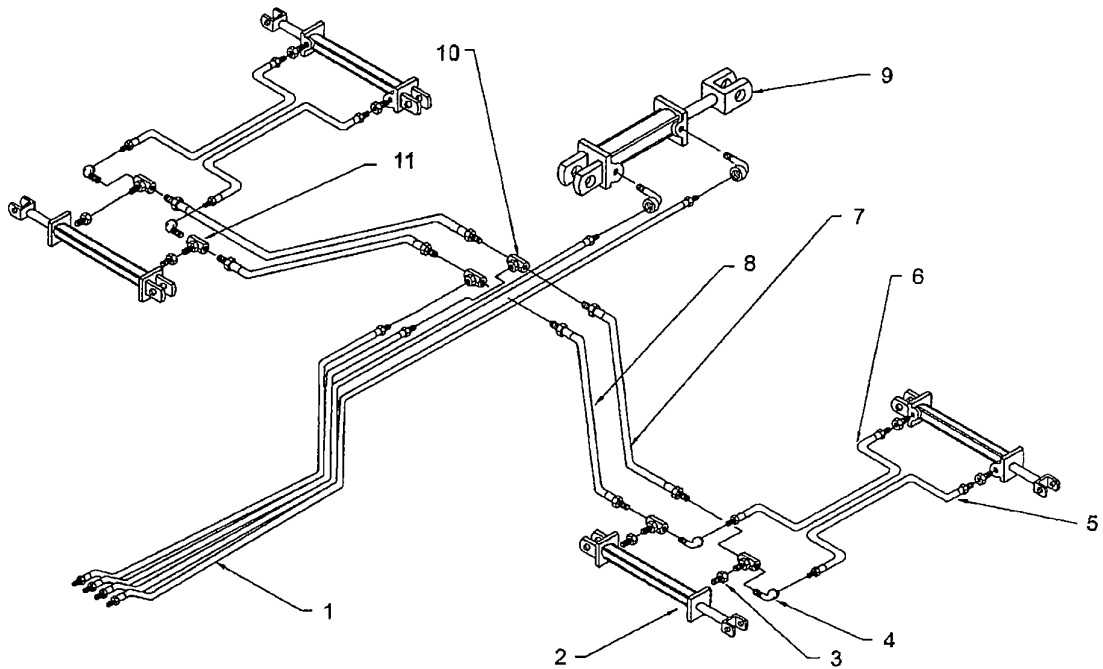

FIGURE 15 - HYDRAULIC CIRCUIT COMPONENTS

Item	Part #	Description	Non-Fold	Folding
1	813077	180" HYDRAULIC LINE	2	4
2	811234	CYLINDER/HYD WING 3" X 16"	0	4
3	208569	FLOW RESTRICTOR - WING CYLINDERS ONLY	0	8
4	207982	90° ELBOW FITTING	2	6
5	803852	96" HYDRAULIC LINE - SMALL & LARGE FRAME MODELS	0	2
6	209227	88" HYDRAULIC LINE - SMALL FRAME MODELS	0	2
	207979	84" HYDRAULIC LINE - LARGE FRAME MODELS	0	2
7	605387	60" HYDRAULIC LINE - LARGE FRAME MODELS	0	2
	803858	36" HYDRAULIC LINE - SMALL FRAME MODELS	0	2
8	208201	38" HYDRAULIC LINE - LARGE FRAME MODELS	0	2
	803860	16" HYDRAULIC LINE - SMALL FRAME MODELS	0	2
9	811235	CYLINDER/HYD WHEEL LIFT 4" X 8"	1	1
10	207983	FEMALE TEE FITTING	0	2

BALK BREAKER KIT			
Item	Part #	Description	Qty
1	303690	HHCS 5/8" x 8"	4
	303956	WASHER/LOCK 5/8"	4
	304008	NUT/HEX 5/8" NC	4
2	209707	CONNECTOR PLATE	2
3	209553	CUFF ASSEMBLY	2
4	209550	SHANK CONNECTOR	1
5	207434	16" SHANK	1
6	303678	HHCS 5/8" x 2-1/2"	1
	303956	WASHER/LOCK 5/8"	1
	304008	NUT/HEX 5/8" NC	1
7	603984	5/8" U-BOLT	1
	303956	WASHER/LOCK 5/8"	1
	304008	NUT/HEX 5/8" NC	1
8	303910	BOLT/PLOW 1/2" x 2-1/2"	2
	303955	WASHER/LOCK 1/2"	2
	303971	WASHER/FLAT 1/2"	2
	304007	NUT/HEX 1/2" NC	2
9	209408	8" SWEEP	1
299088		COMPLETE KIT	

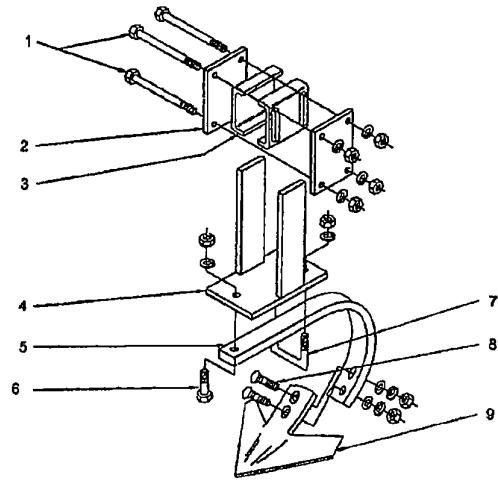

FIGURE 16 - BALK BREAKER KIT

FURROW FILLER KIT			
Item	Part #	Description	Qty
1	303651	HHCS 1/2" x 1-1/2"	3
	303955	WASHER/LOCK 1/2"	3
	304007	NUT/HEX 1/2" NC	
2	206629	SPACER SPOOL	1
3	204000	16" DISC	1
	204001	18" DISC	1
4	203986	BUTT PLATE	1
5	303958	WASHER/LOCK 7/8"	1
6	304010	NUT/HEX 7/8" NC	1
201048		KIT WITHOUT DISC	2

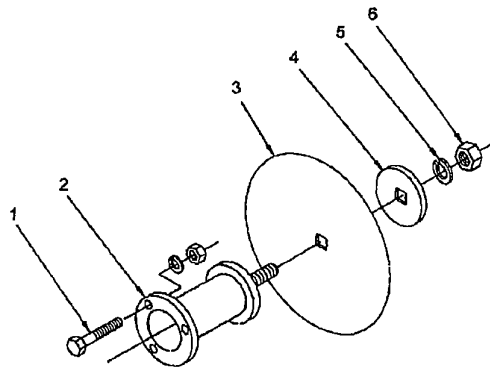

FIGURE 17 - FURROW FILLER KIT**

** The furrow filler kit should not be used on small frame units with 6 and 7 disc wings due to interference when wings are folded.

FURROW SCRAPER KIT			
Item	Part #	Description	Qty
1	303859	Carr. BOLT 1/2"X1-1/2"	4
	303955	LOCK/WASHER 1/2"	4
	304007	HEX NUT 1/2" - NC	4
2	807096	L.H. SCRAPER ARM	1
	807097	R.H. SCAPER ARM	1
3	805000	SCRAPER BLADE	2
	804999	SHOULDER RIVOT	4
4	809693	SCRAPER BAR	2
	809694	COMPLETE SCRAPER KIT	

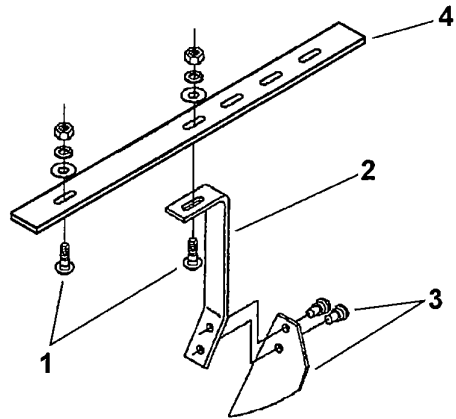
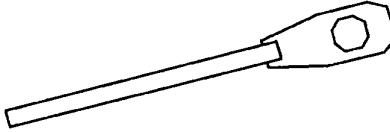

FIGURE 18 - FURROW FILLER SCRAPER KIT



209953 GANG BOLT WRENCH

MISCELLANEOUS HARDWARE BY SIZE				
Size	Part Number By Item			
	Lockwasher	Flatwasher	Hex Nut	Hex Locknut
1/4"	303951	-	304003	-
5/16"	303952	303968	304004	-
3/8"	303953	303969	304005	304018
7/16"	303954	303970	304006	304019
1/2"	303955	303971	304007	304020
5/8"	303956	303972	304008	304021
3/4"	303957	303973	304009	304022
7/8"	303958	303974	304010	304023
1"	303959	303975	304011	304024
1-1/8"	303960	303976	304012	304025
1-1/4"	303961	303977	304013	304026

